

DATE:1400.07.03

COLUMN NO: 6

RAFTER NO: 31

T NO: 160

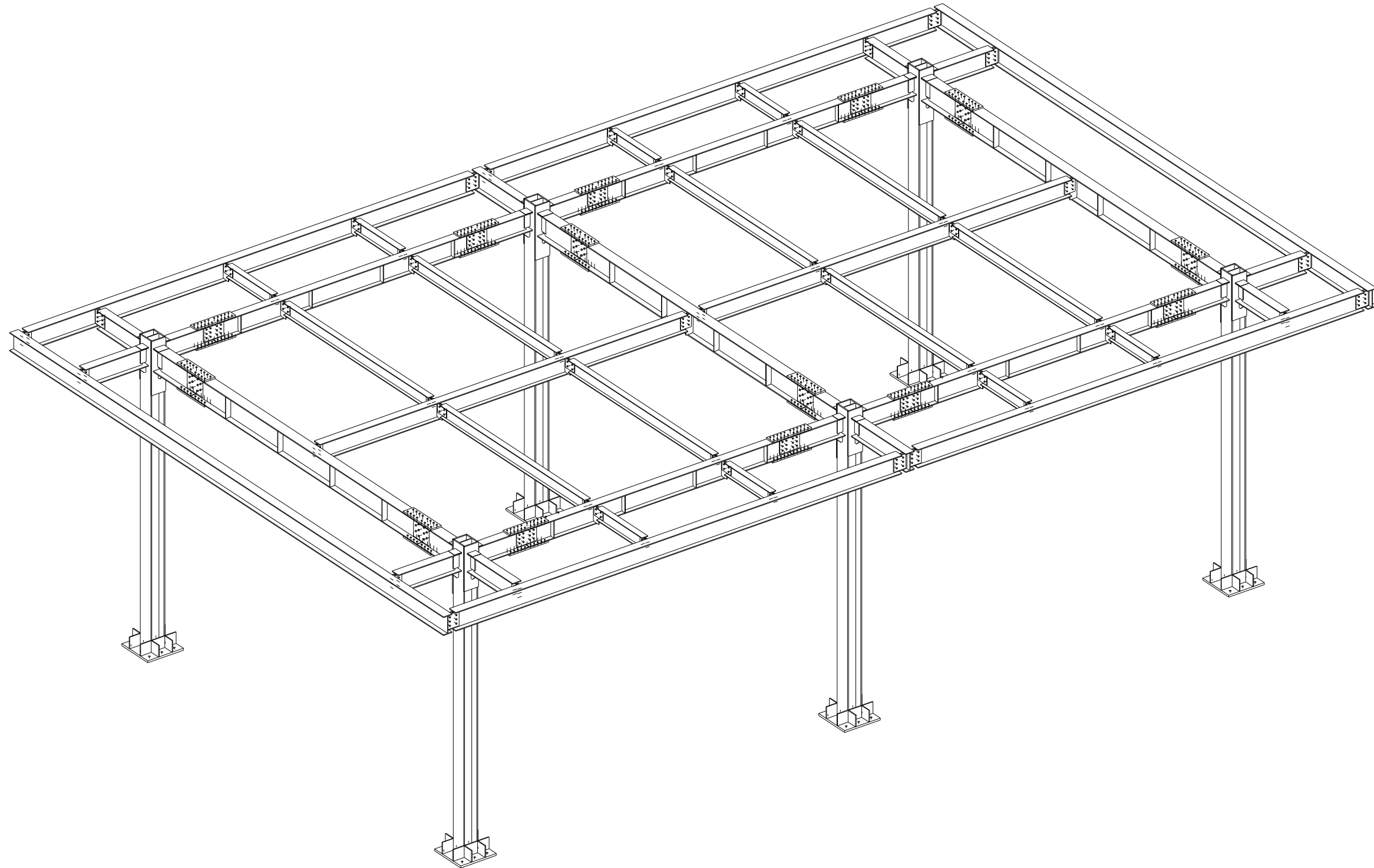

GHOM- GURD STRUCURE

1:50

DISPOSITION :

- NO COMMENT
- COMMENTS AS MARKED .FABRICATION
- REJECT. DOCUMENT TO BE REVISED
- USED FOR INFORMATION ONLY

No	REV MARK	REVISION DESCRIPTION	REV. DATE
CLIENT			
PRINT DATE FOR FABRICATION:			
PROJECT NAME	قم - سازه نگهداری		
DRAWING NAME	[1]	ISSUED	
MODELLED BY	09124932441	SCALE	AS SHOWN
CHECKED BY		REVISION No.	0

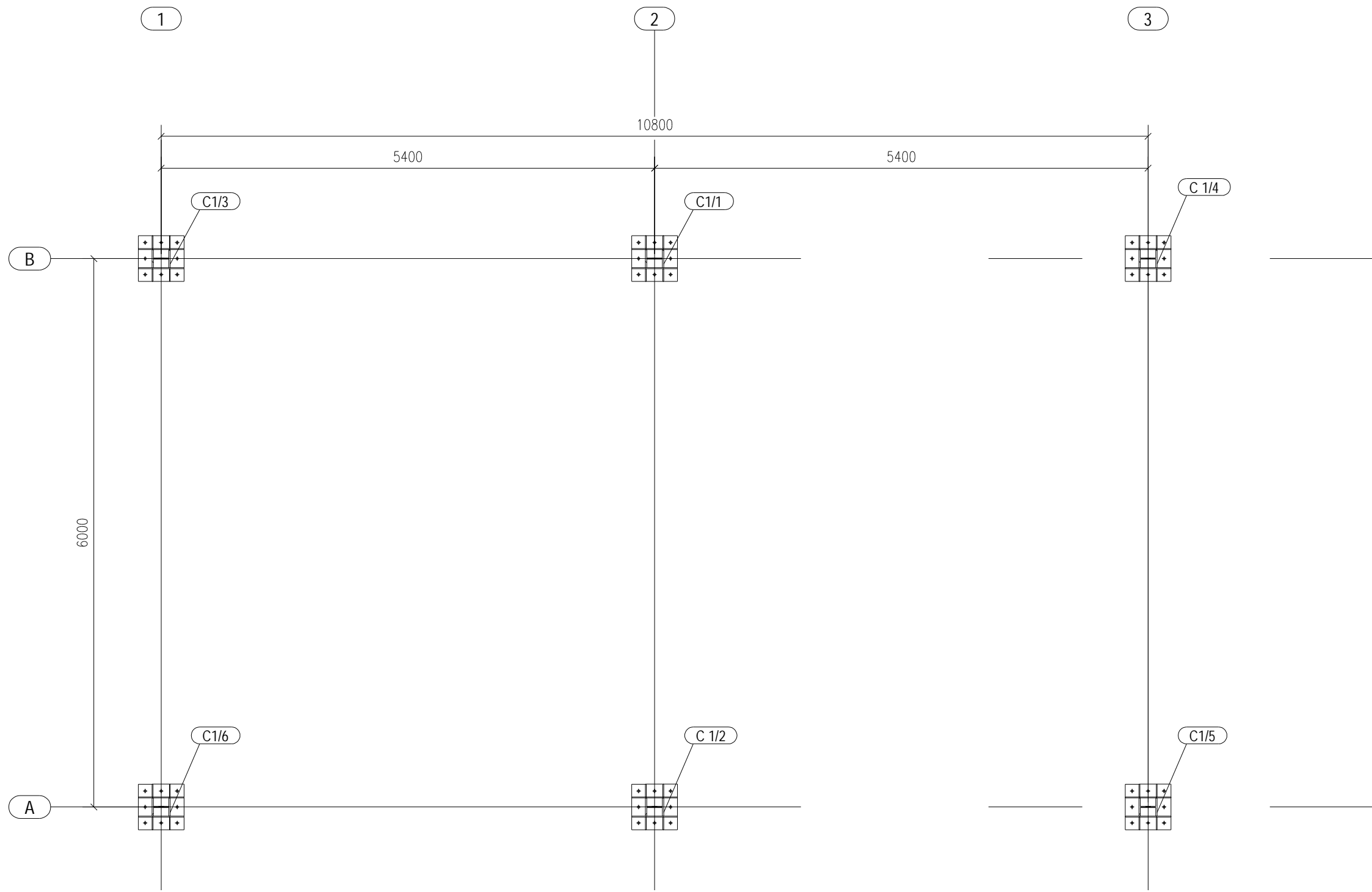

PLAN - .775
1:50

No	REV MARK	REVISION DESCRIPTION	REV. DATE
CLIENT			
PRINT DATE FOR FABRICATION:			
PROJECT NAME	قم - سازه نگهدارنده		
DRAWING NAME	[2]	ISSUED	
MODELLED BY	09124932441	SCALE	AS SHOWN
CHECKED BY		REVISION No.	0

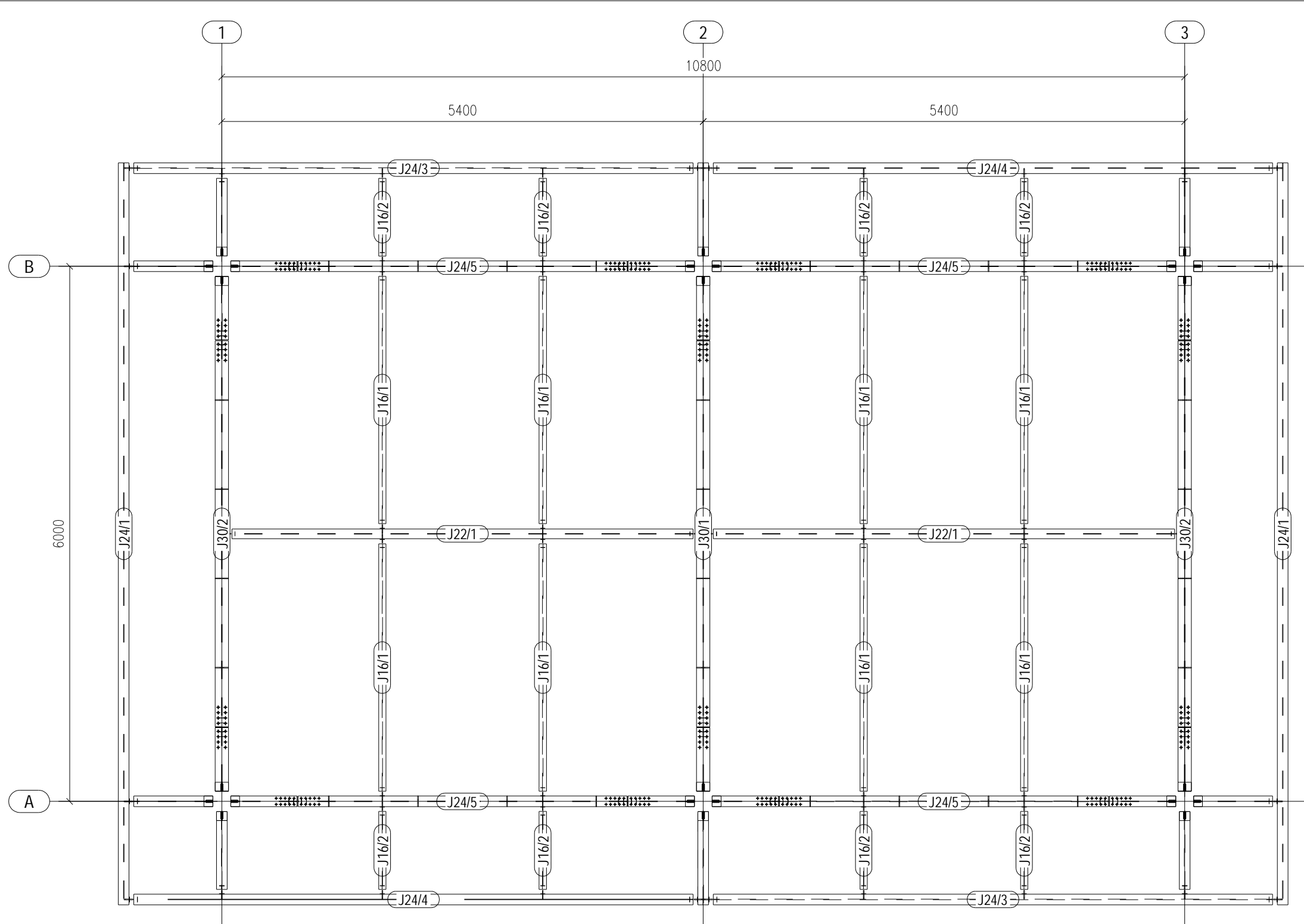

PLAN 3.17
1:50

No	REV MARK	REVISION DESCRIPTION	REV. DATE
CLIENT			
PRINT DATE FOR FABRICATION:			
PROJECT NAME	قم - سازه نگهداری		
DRAWING NAME	[3]	ISSUED	
MODELLED BY	09124932441	SCALE	AS SHOWN
CHECKED BY		REVISION No.	0

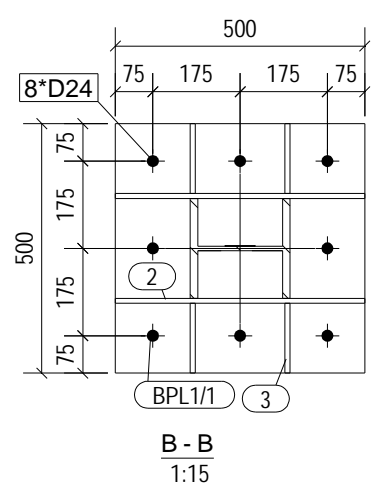
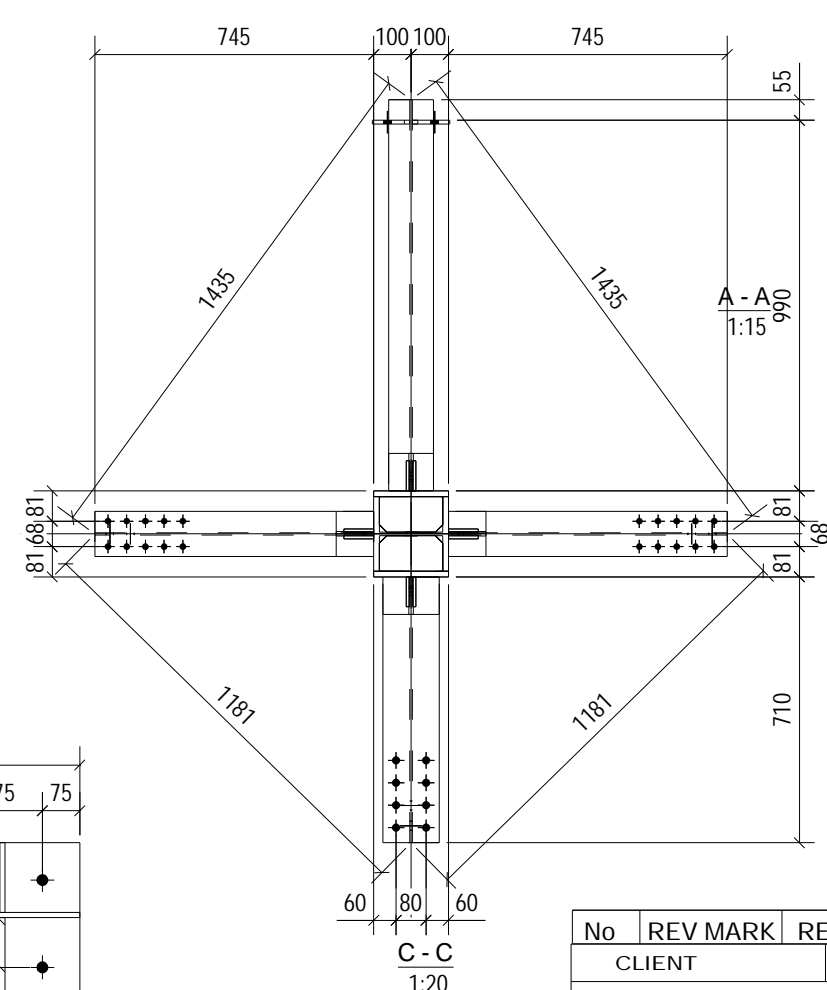
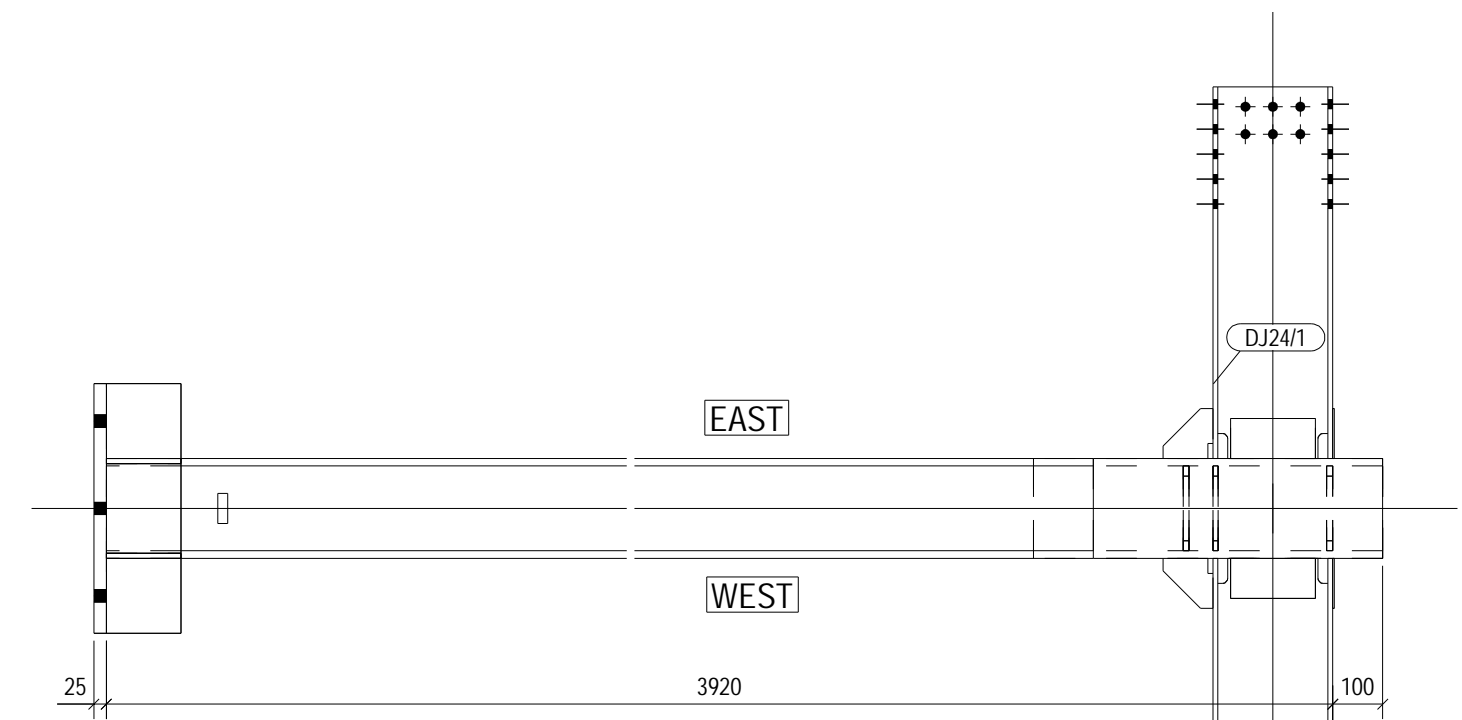
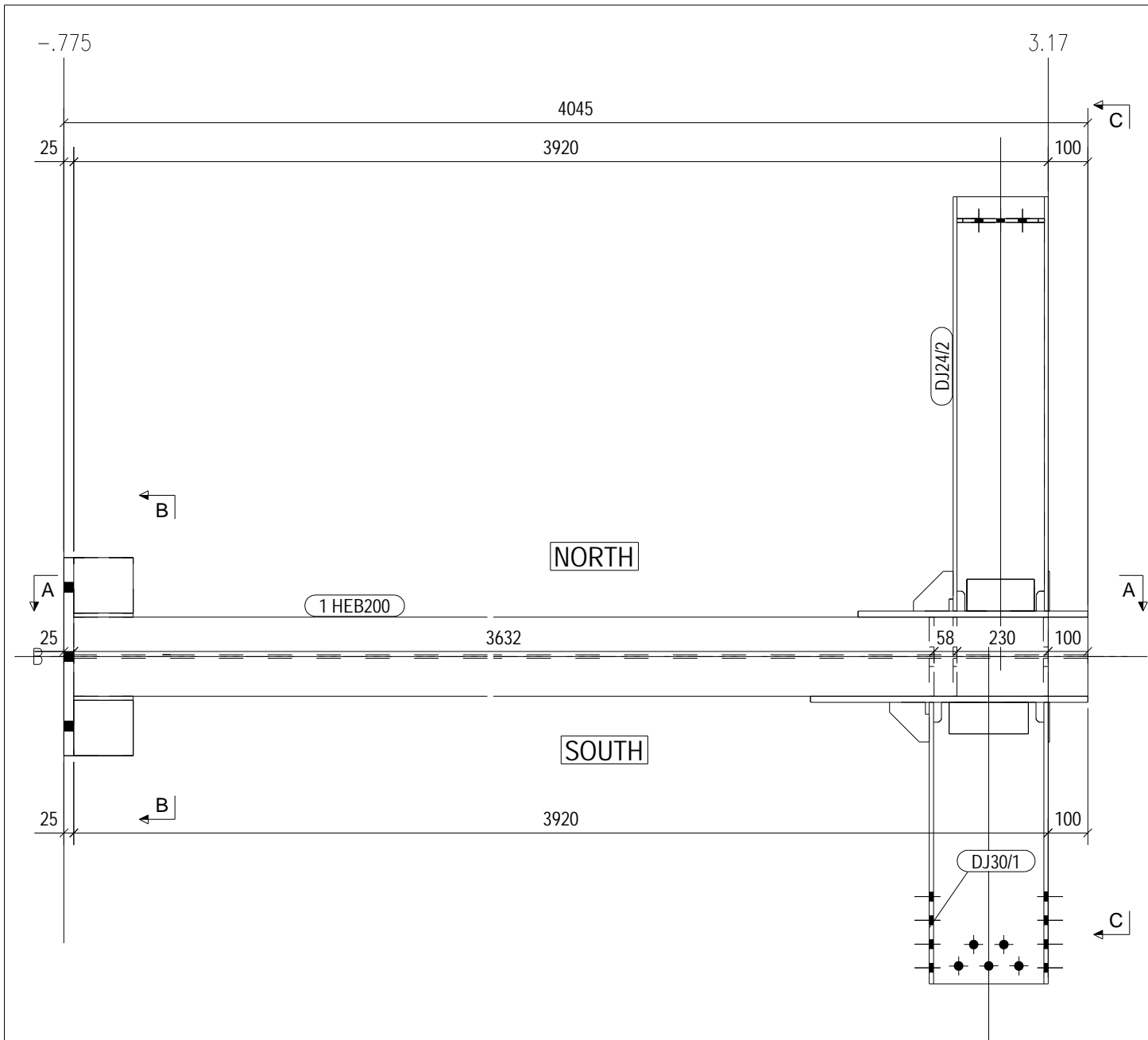

C1/1 No = 1

MATERIAL LIST FOR ASSEMBLY MK'D C1/1 1 No. Required						
Mark	Profile	Material	No.	Length	Area	Weight
1	HEB200	S235JR	1	4020	4.6	246.4
2	PL10*150	S235JR	2	500	0.2	5.9
3	PL10*150	S235JR	4	140	0.0	1.6
4	PL10*95	S235JR	2	170	0.0	1.2
11	PL1*20	S235JR	1	60	0.0	0.0
33	PL15*200	S235JR	1	700	0.3	16.5
34	PL15*200	S235JR	1	580	0.3	13.7
35	PL12*95	S235JR	4	170	0.0	1.5
BPL1/1	PL25*500	S235JR	1	500	0.6	49.1
DJ24/1	Assembly		2		0.8	25.9
DJ24/2	Assembly		1		1.2	38.6
DJ30/1	Assembly		1		0.9	33.5
Total					10.2	476.3

No	REV MARK	REVISION DESCRIPTION	REV. DATE
CLIENT			
PRINT DATE FOR FABRICATION:			
PROJECT NAME	قم - سازه نگهداری		
DRAWING NAME	[C1.1]	ISSUED	
MODELLED BY	09124932441	SCALE	AS SHOWN
CHECKED BY		REVISION No.	0

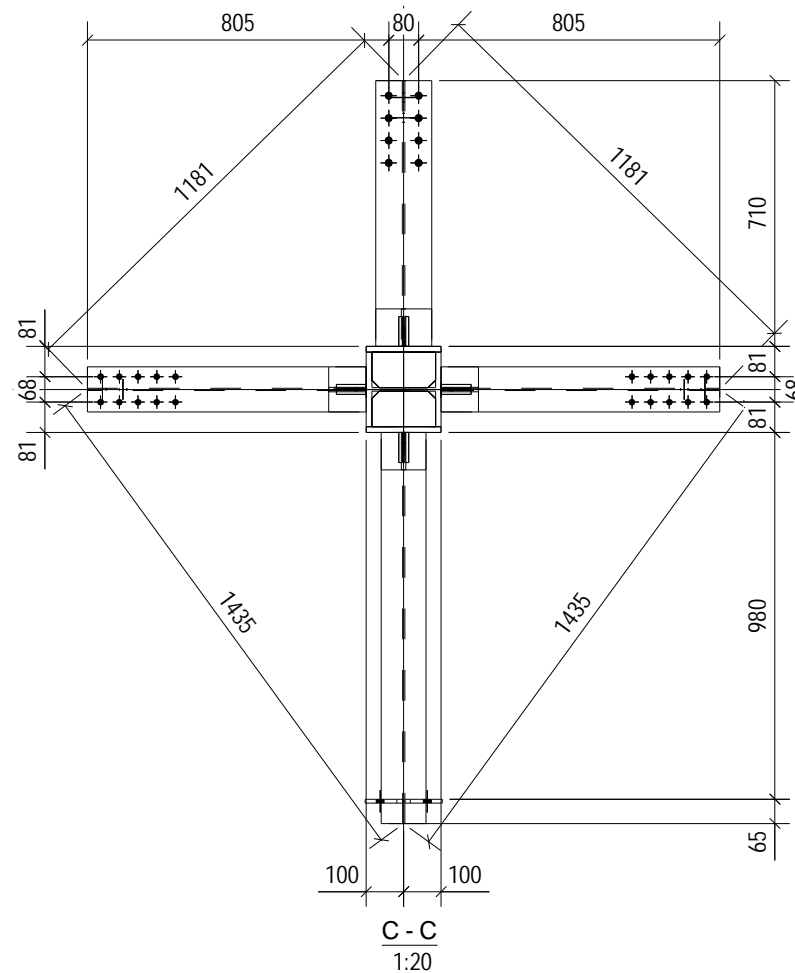
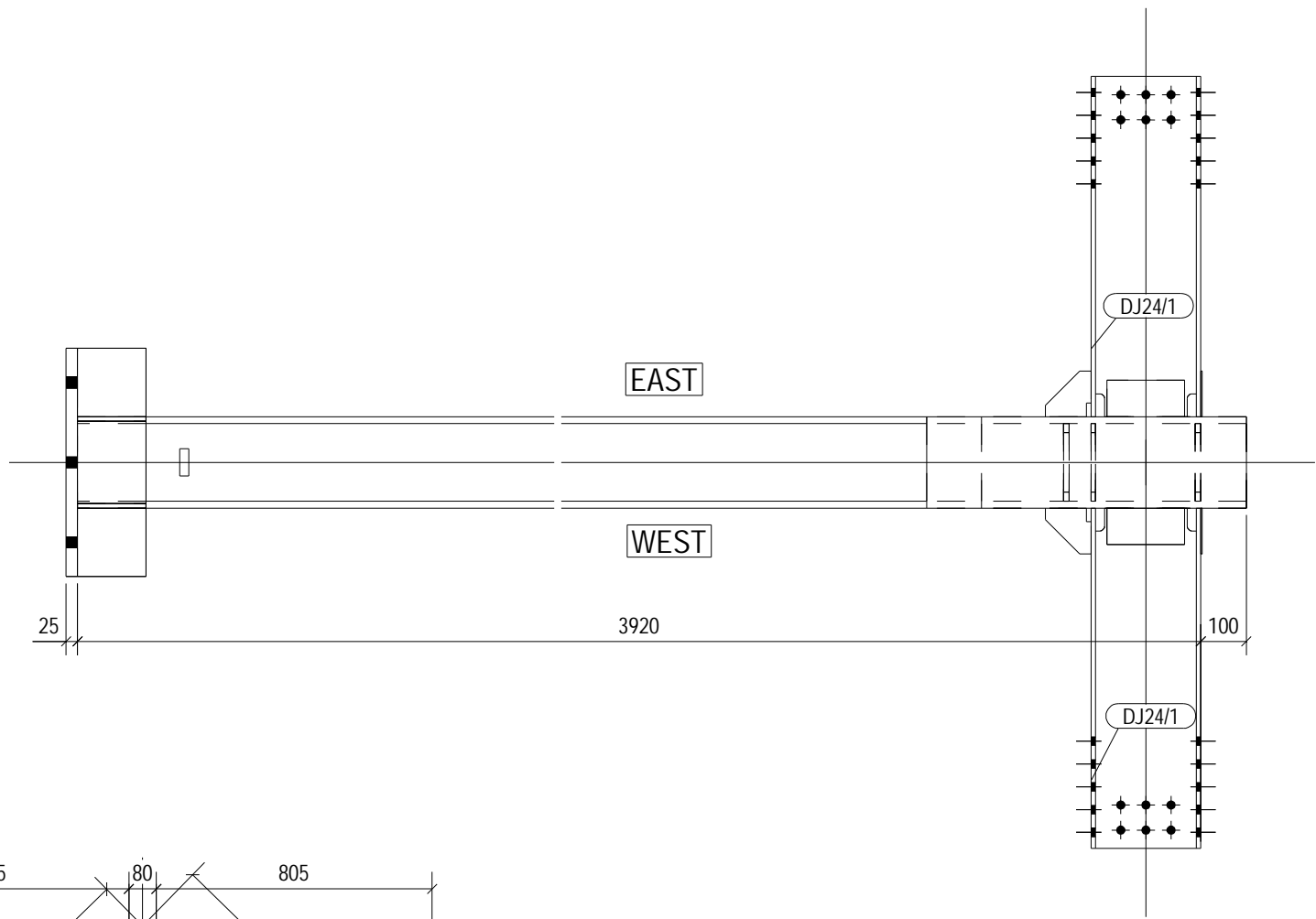
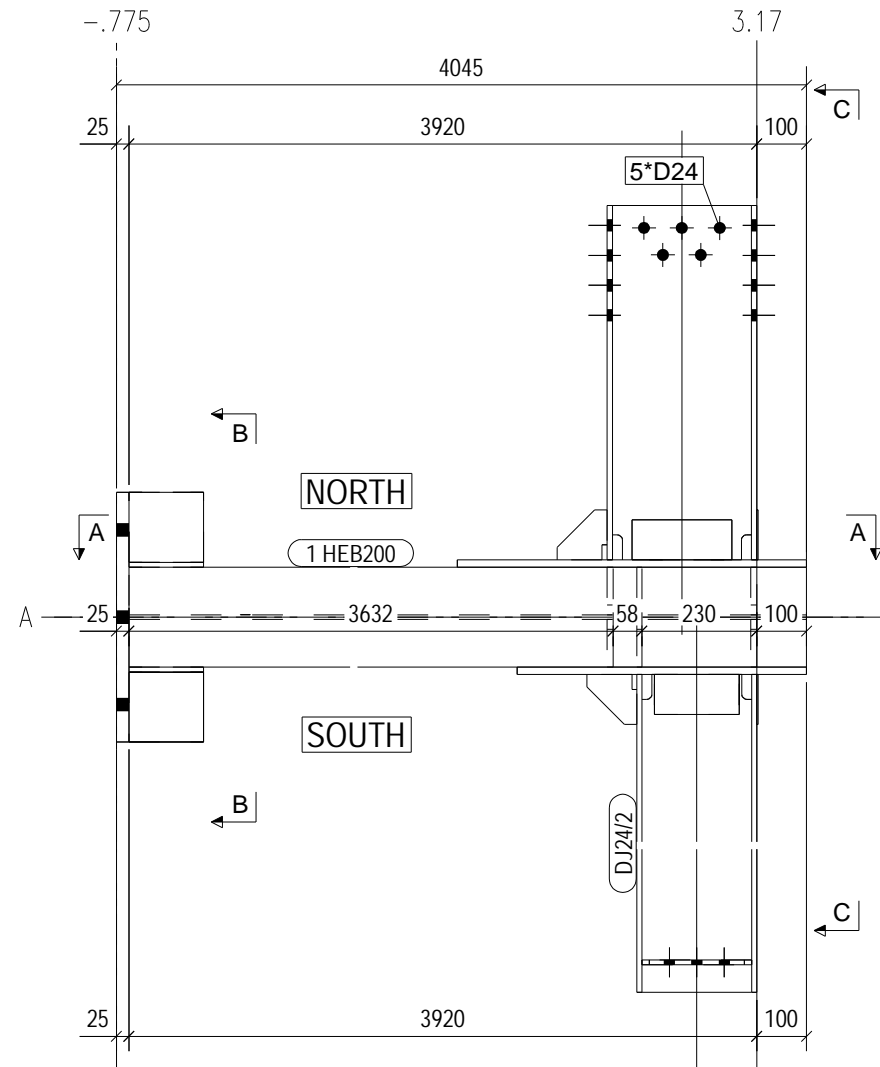

A - A
1:15

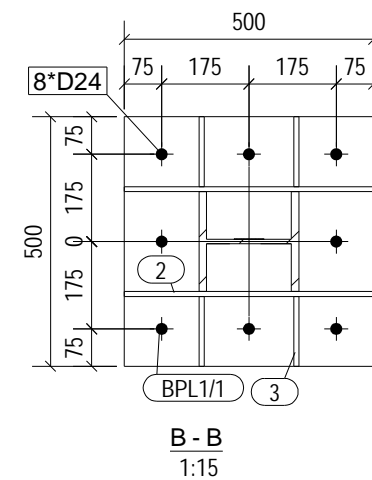

C1/2 No = 1

MATERIAL LIST FOR ASSEMBLY MK'D						
Mark	Profile	Material	No.	Length	Area	Weight
1	HEB200	S235JR	1	4020	4.6	246.4
2	PL10*150	S235JR	2	500	0.2	5.9
3	PL10*150	S235JR	4	140	0.0	1.6
4	PL10*96	S235JR	2	170	0.0	1.2
11	PL1*20	S235JR	1	60	0.0	0.0
33	PL15*200	S235JR	1	700	0.3	16.5
34	PL15*200	S235JR	1	580	0.3	13.7
35	PL12*96	S235JR	4	170	0.0	1.5
BPL1/1	PL25*500	S235JR	1	500	0.6	49.1
DJ24/1	Assembly		2		0.8	25.9
DJ24/2	Assembly		1		1.2	38.6
DJ30/1	Assembly		1		0.9	33.5
Total					10.2	476.3

No	REV MARK	REVISION DESCRIPTION	REV. DATE
CLIENT			
PRINT DATE FOR FABRICATION:			
PROJECT NAME	قم - سازه نگهداری		
DRAWING NAME	[C1.2]	ISSUED	
MODELLED BY	09124932441	SCALE	AS SHOWN
CHECKED BY		REVISION No.	0

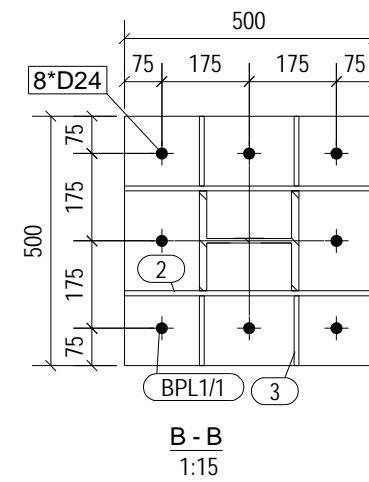
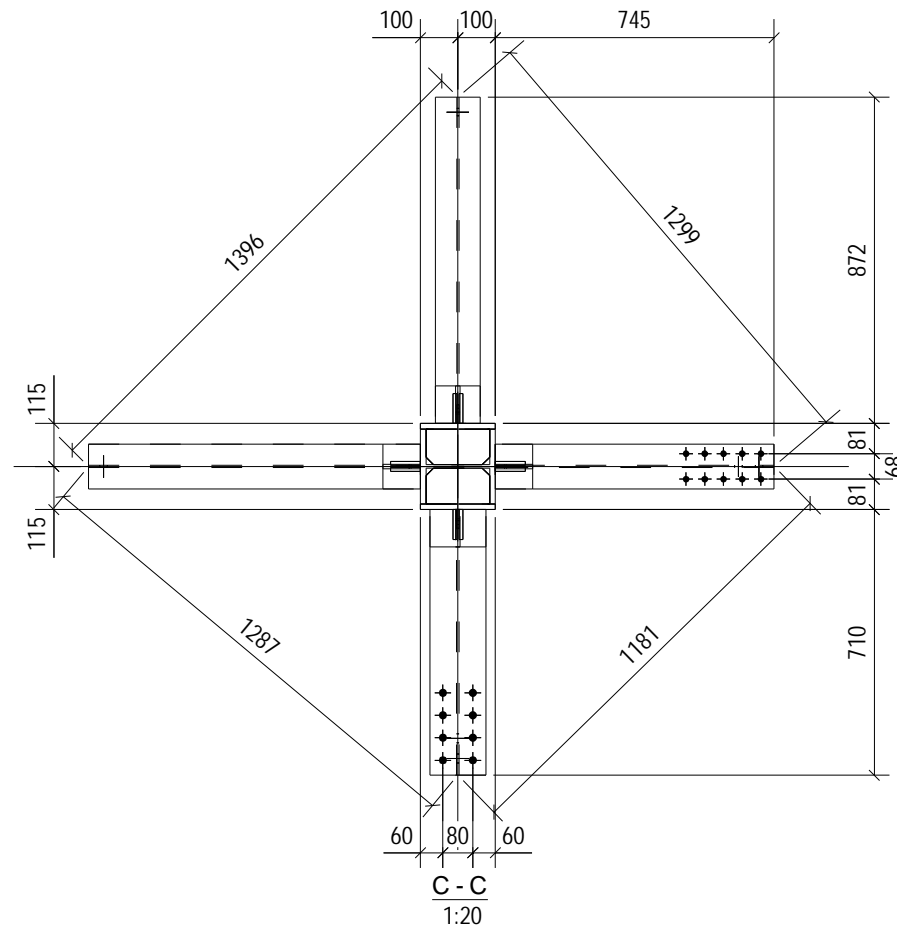
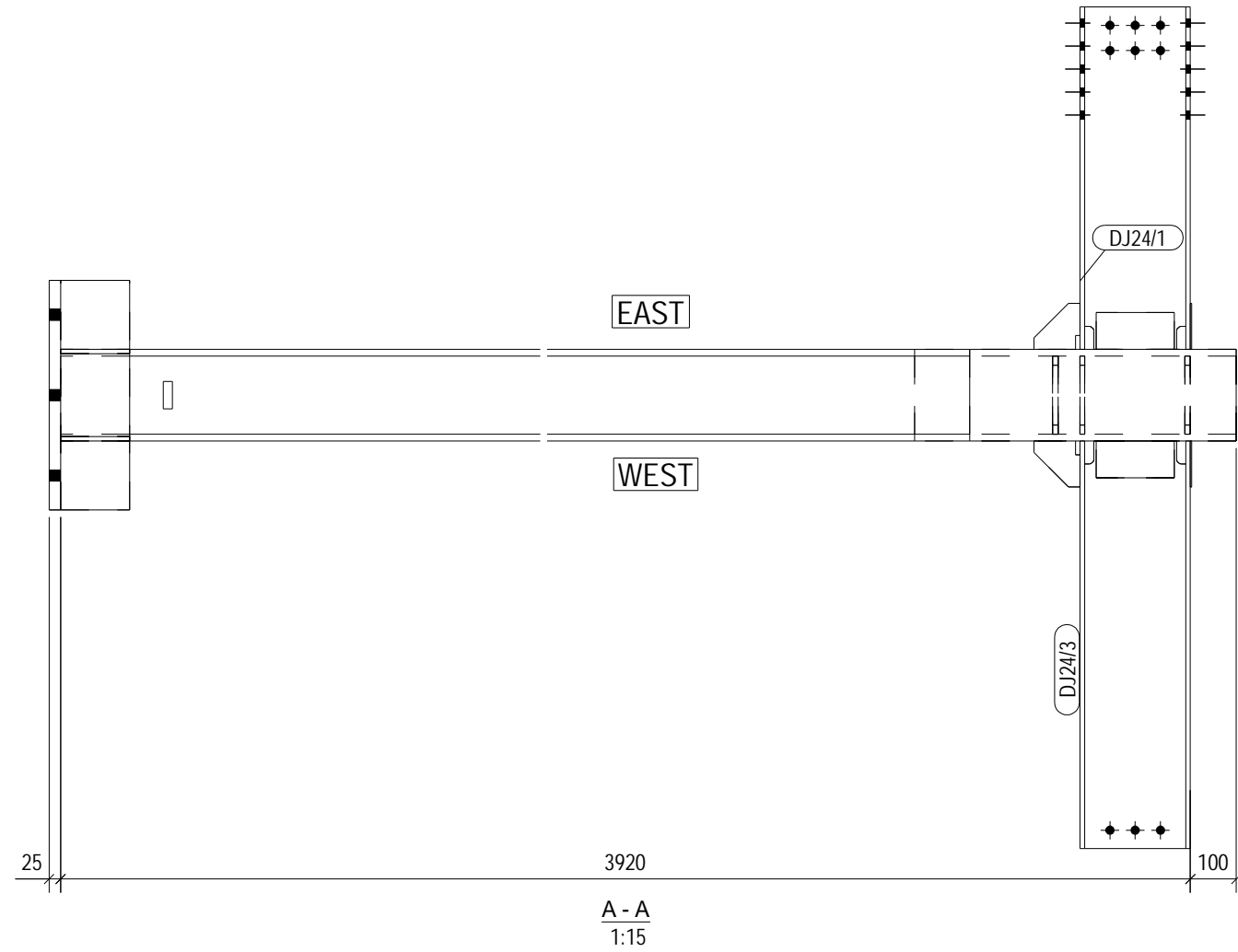
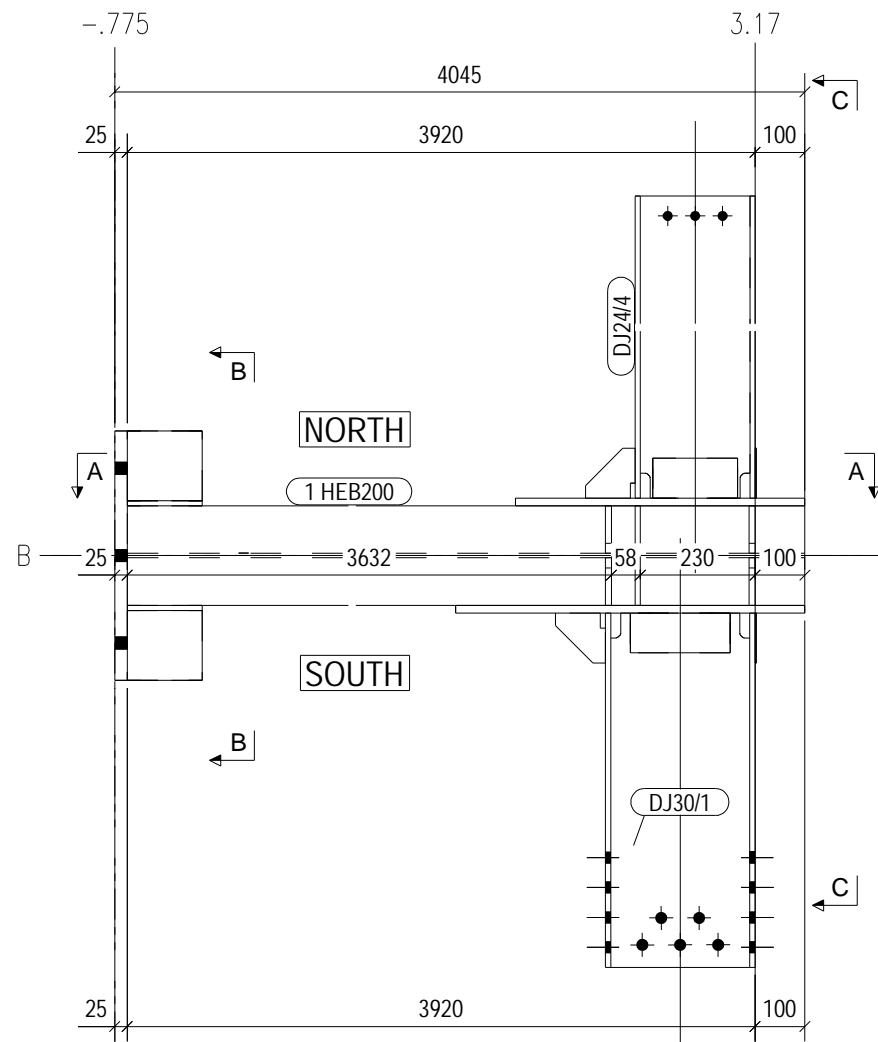

C1/3 No = 1

MATERIAL LIST FOR ASSEMBLY MK'D C1/3 1 No. Required						
Mark	Profile	Material	No.	Length	Area	Weight
1	HEB200	S235JR	1	4020	4.6	246.4
2	PL10*150	S235JR	2	500	0.2	5.9
3	PL10*150	S235JR	4	140	0.0	1.6
4	PL10*95	S235JR	2	170	0.0	1.2
11	PL1*20	S235JR	1	60	0.0	0.0
33	PL15*200	S235JR	1	700	0.3	16.5
34	PL15*200	S235JR	1	580	0.3	13.7
35	PL12*96	S235JR	4	170	0.0	1.5
BPL1/1	PL25*500	S235JR	1	500	0.6	49.1
DJ24/1	Assembly		1		0.8	25.9
DJ24/3	Assembly		1		0.9	30.3
DJ24/4	Assembly		1		0.9	29.8
DJ30/1	Assembly		1		0.9	33.5
Total				10.1		472.0

No	REV MARK	REVISION DESCRIPTION	REV. DATE
CLIENT			
PRINT DATE FOR FABRICATION:			
PROJECT NAME		قم - سازه نگهداری	
DRAWING NAME		[C1.3]	ISSUED
MODELLED BY		09124932441	SCALE AS SHOWN
CHECKED BY			REVISION No. 0

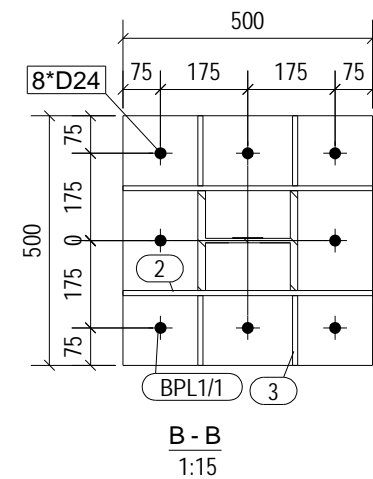
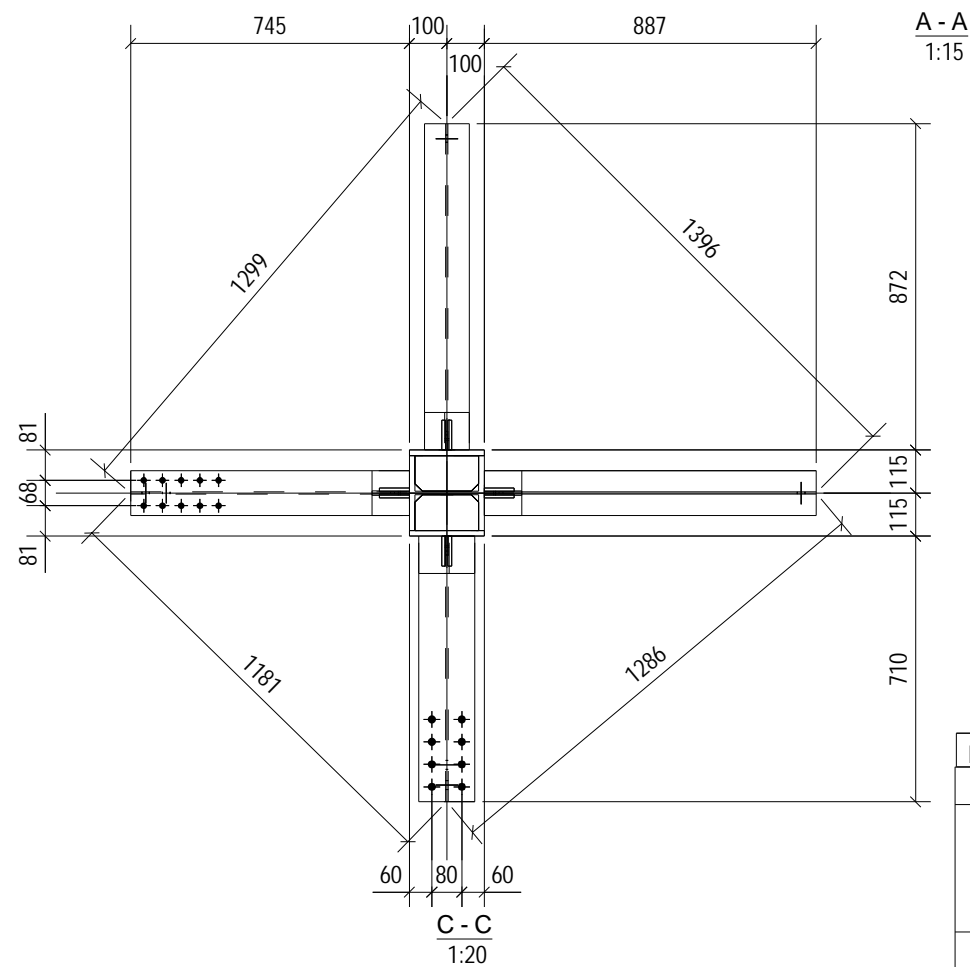
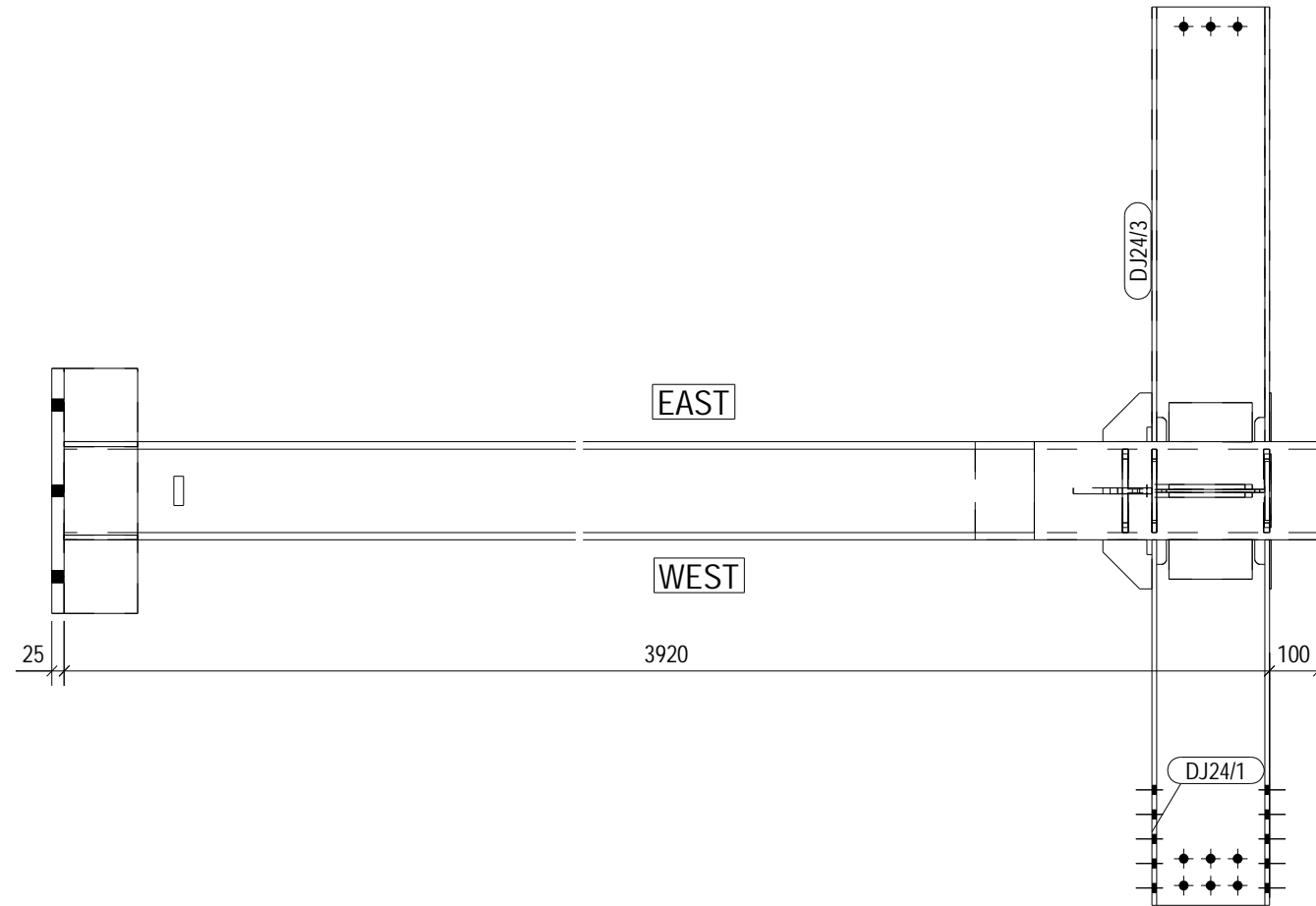
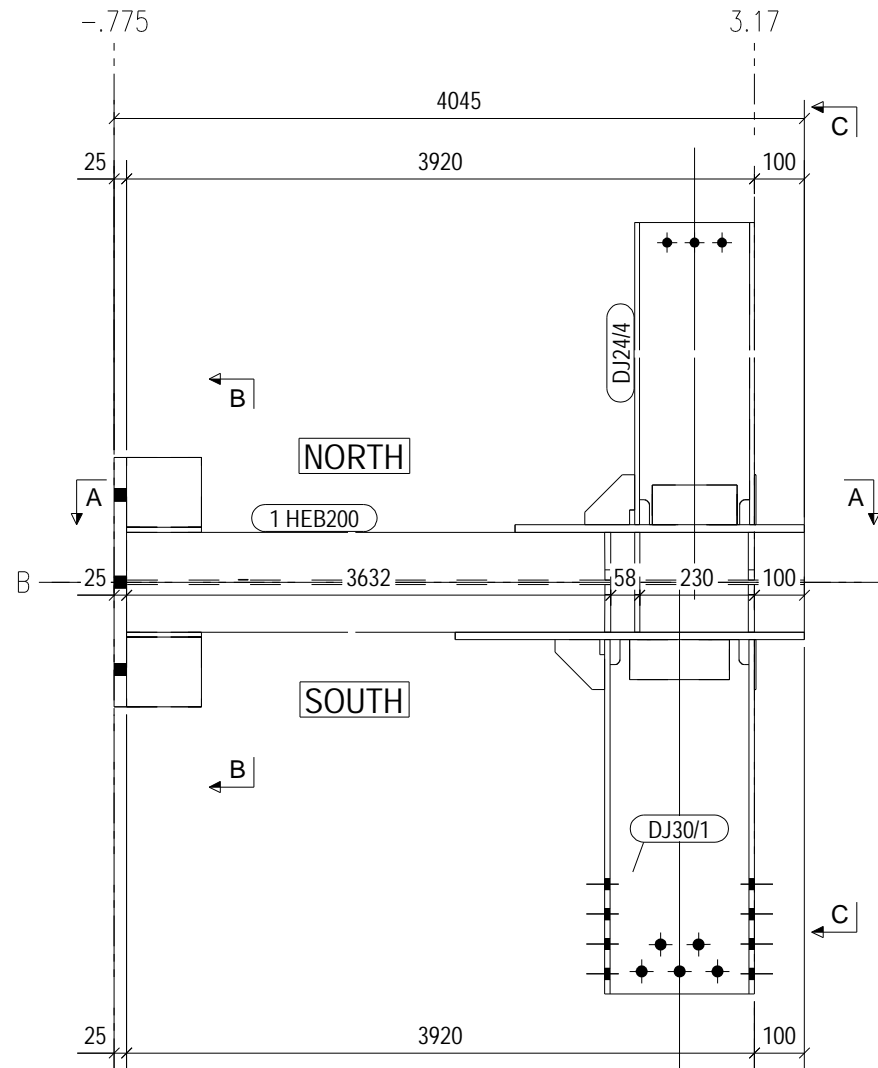

C1/4 No = 1

MATERIAL LIST FOR ASSEMBLY MK'D C1/4 1 No. Required						
Mark	Profile	Material	No.	Length	Area	Weight
1	HEB200	S235JR	1	4020	4.6	246.4
2	PL10*150	S235JR	2	500	0.2	5.9
3	PL10*150	S235JR	4	140	0.0	1.6
4	PL10*95	S235JR	2	170	0.0	1.2
11	PL1*20	S235JR	1	60	0.0	0.0
33	PL15*200	S235JR	1	700	0.3	16.5
34	PL15*200	S235JR	1	580	0.3	13.7
35	PL12*95	S235JR	4	170	0.0	1.5
BPL1/1	PL25*500	S235JR	1	500	0.6	49.1
DJ24/1	Assembly		1		0.8	25.9
DJ24/3	Assembly		1		0.9	30.3
DJ24/4	Assembly		1		0.9	29.8
DJ30/1	Assembly		1		0.9	33.5
Total				10.1		472.0

No	REV MARK	REVISION DESCRIPTION	REV. DATE
CLIENT			
PRINT DATE FOR FABRICATION:			
PROJECT NAME		قم - سازه نگهداری	
DRAWING NAME		[C1.4]	ISSUED
MODELLED BY		09124932441	SCALE AS SHOWN
CHECKED BY			REVISION No. 0

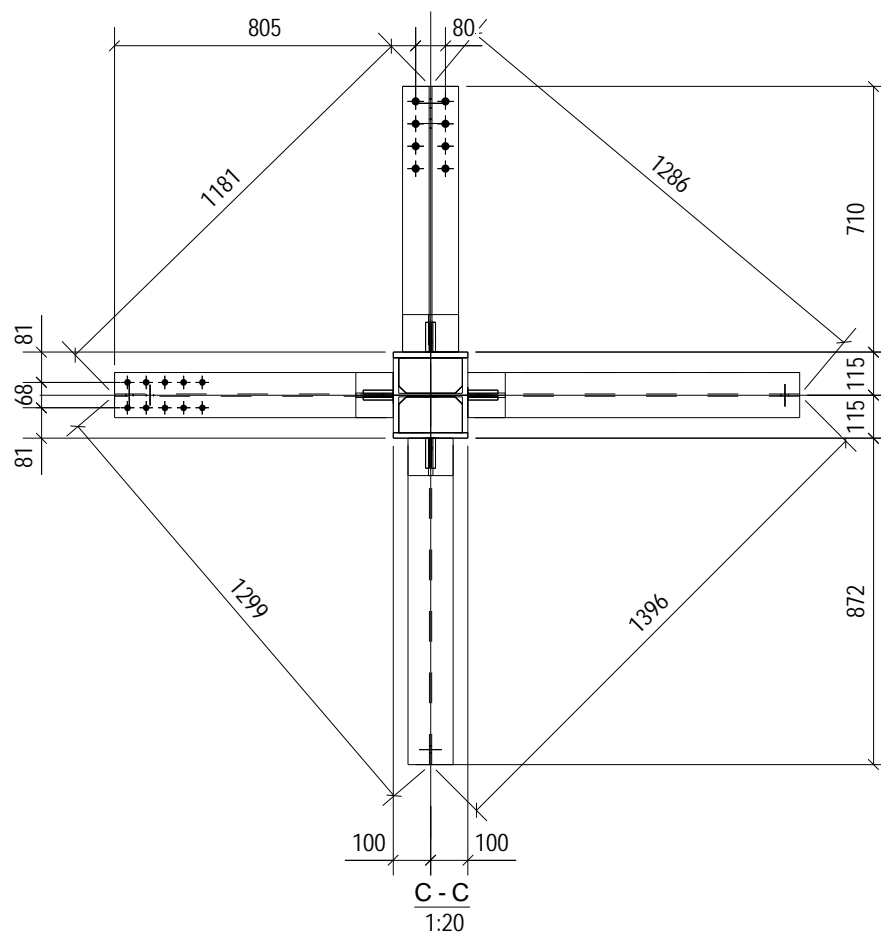
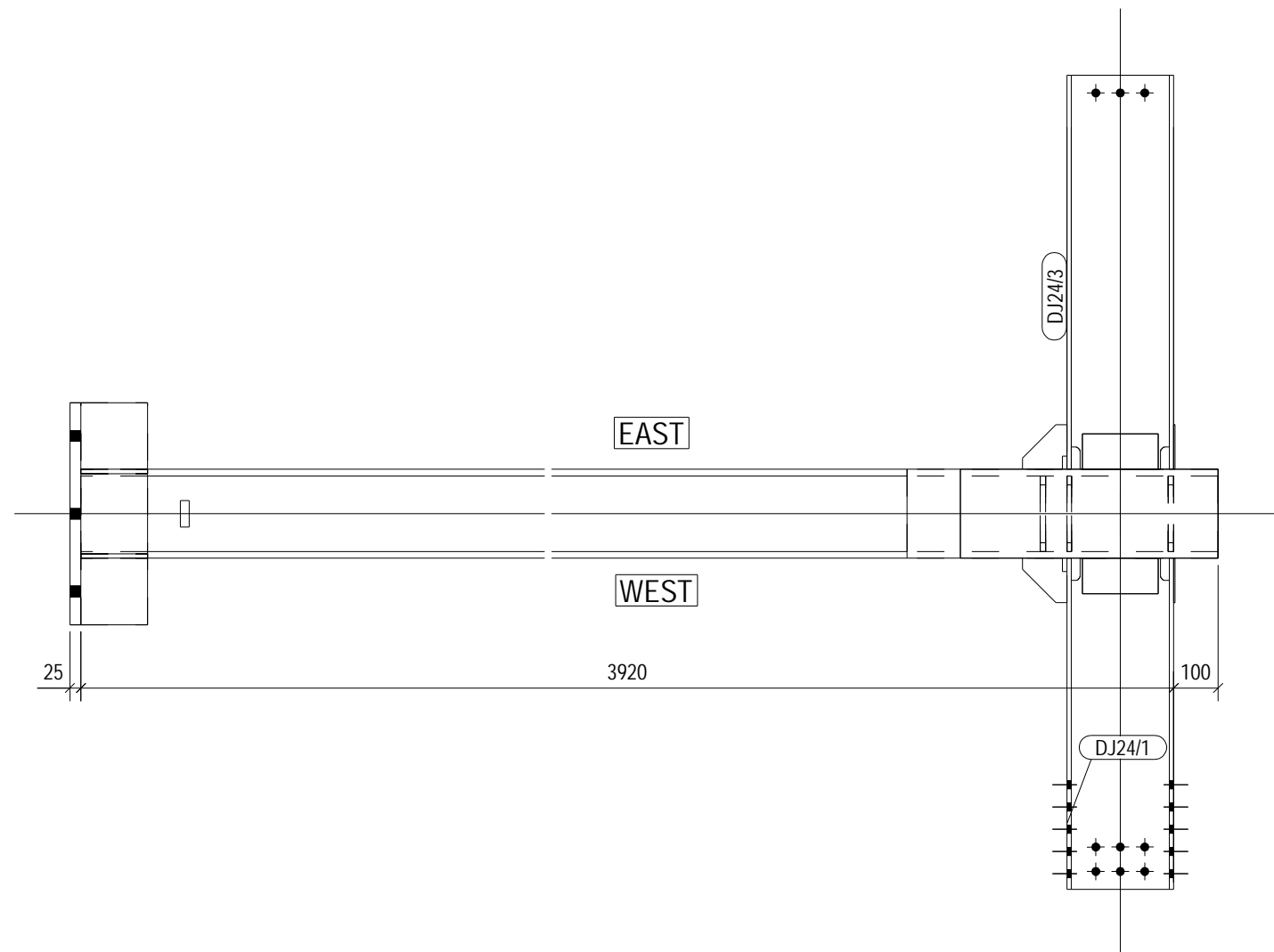
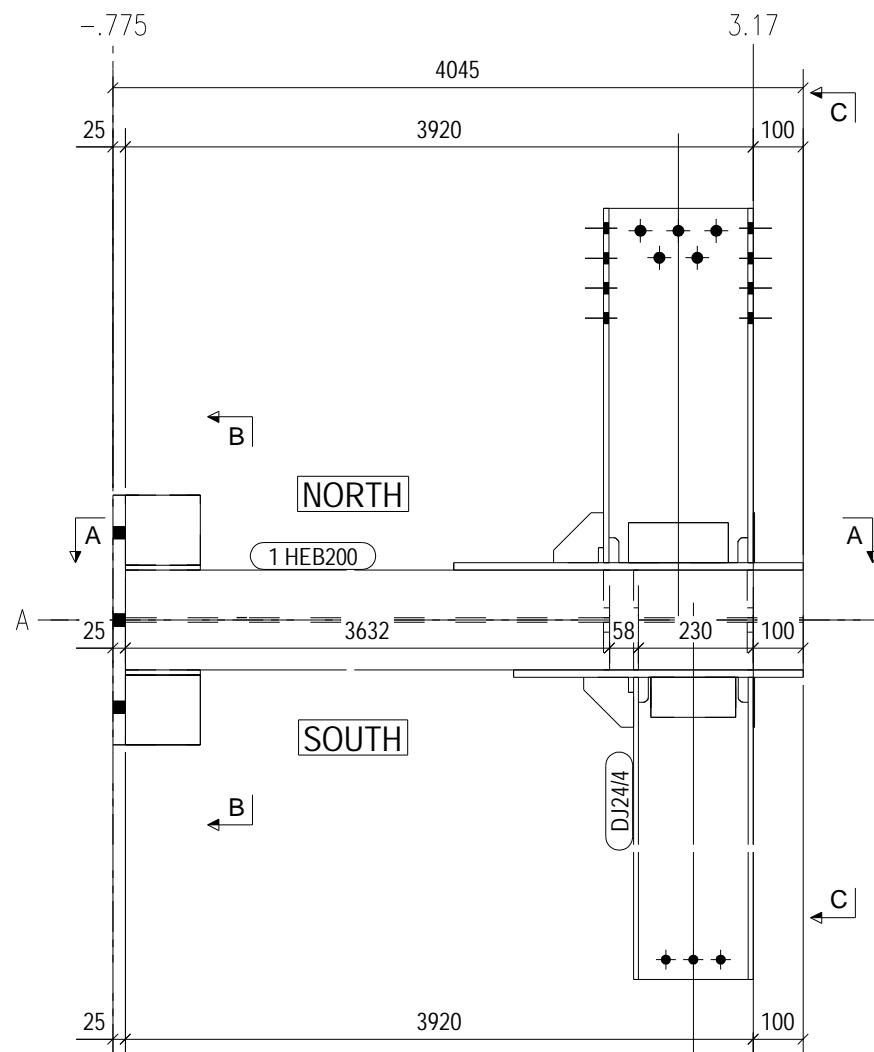

A - A
1:15

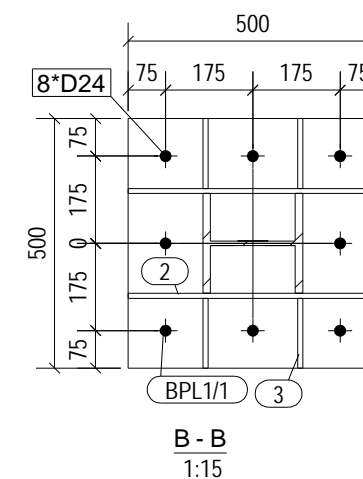

C1/5 No = 1

MATERIAL LIST FOR ASSEMBLY MK'D C1/5 1 No. Required						
Mark	Profile	Material	No.	Length	Area	Weight
1	HEB200	S235JR	1	4020	4.6	246.4
2	PL10*150	S235JR	2	500	0.2	5.9
3	PL10*150	S235JR	4	140	0.0	1.6
4	PL10*96	S235JR	2	170	0.0	1.2
11	PL1*20	S235JR	1	60	0.0	0.0
33	PL15*200	S235JR	1	700	0.3	16.5
34	PL15*200	S235JR	1	580	0.3	13.7
35	PL12*96	S235JR	4	170	0.0	1.5
BPL1/1	PL25*500	S235JR	1	500	0.6	49.1
DJ24/1	Assembly		1		0.8	25.9
DJ24/3	Assembly		1		0.9	30.3
DJ24/4	Assembly		1		0.9	29.8
DJ30/1	Assembly		1		0.9	33.5
Total				10.1		472.0

No	REV MARK	REVISION DESCRIPTION	REV. DATE
CLIENT			
PRINT DATE FOR FABRICATION:			
PROJECT NAME	قم - سازه نگهداری		
DRAWING NAME	[C1.5]	ISSUED	
MODELLED BY	09124932441	SCALE AS SHOWN	
CHECKED BY		REVISION No.	0

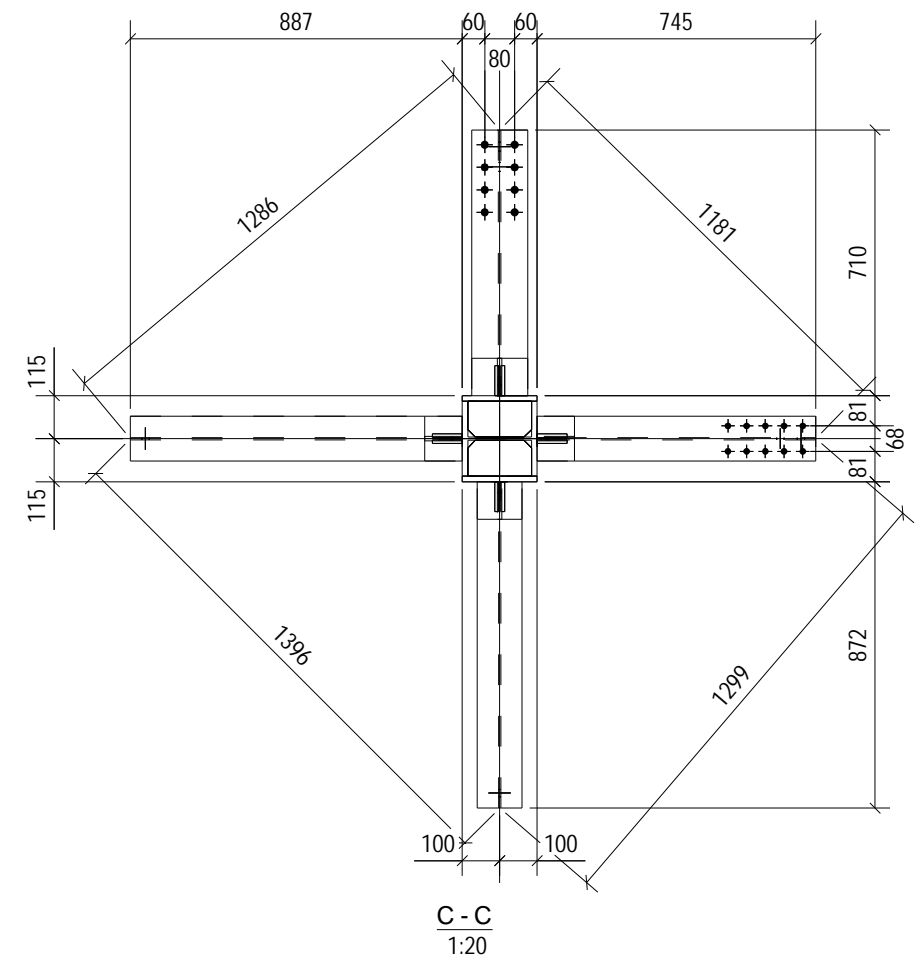
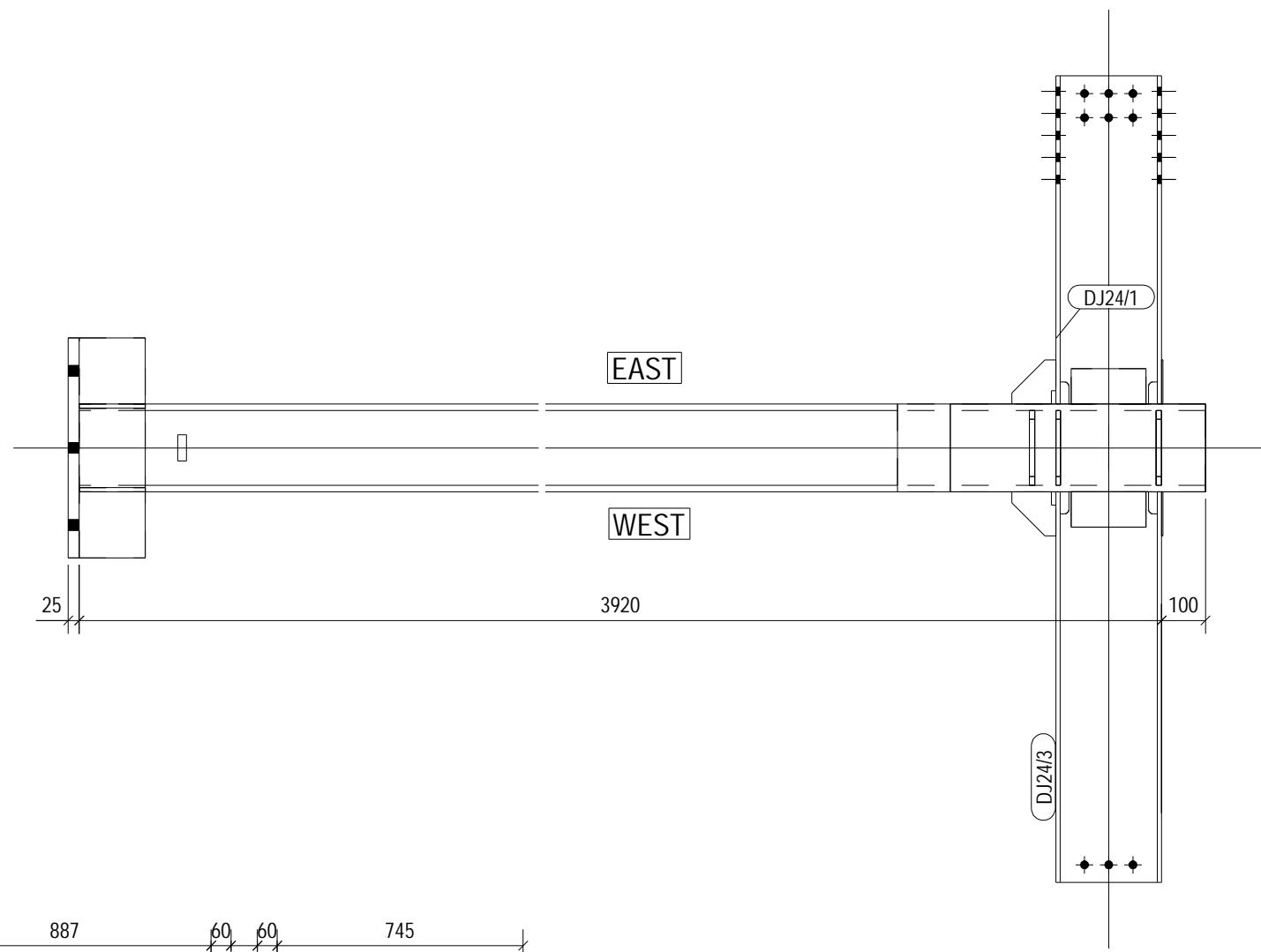
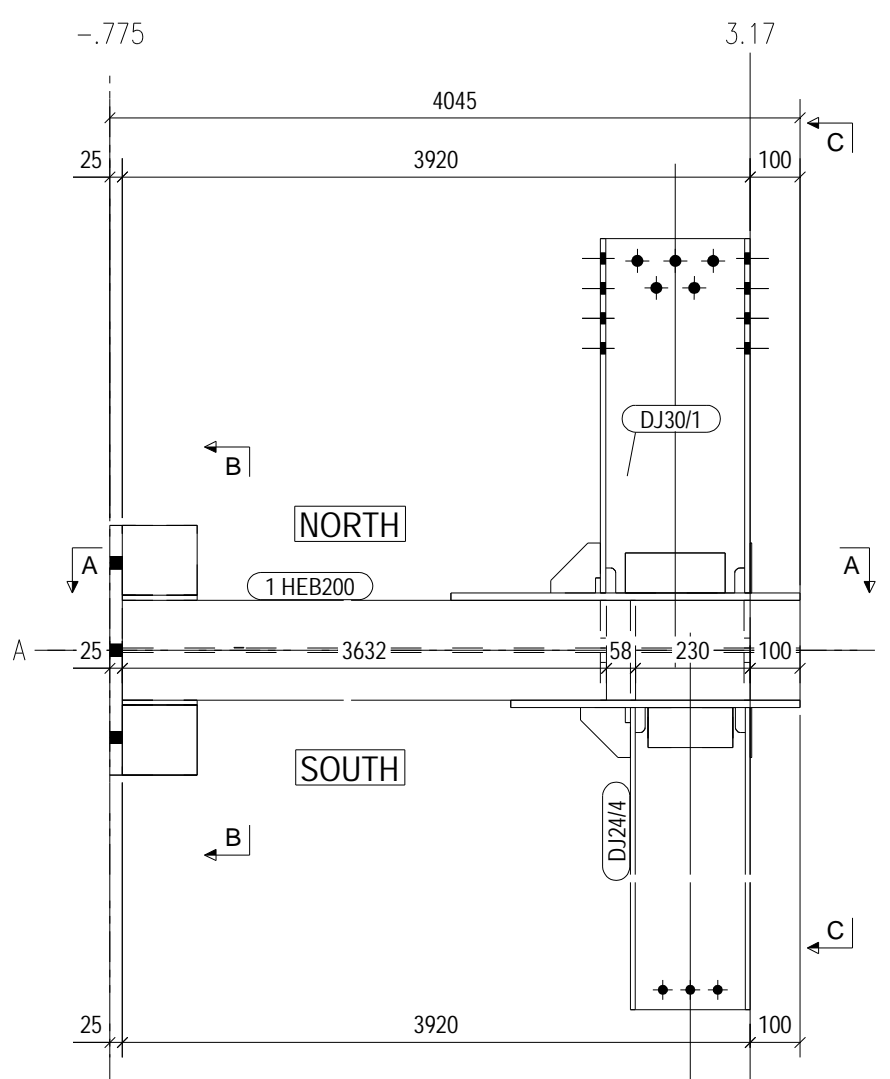

A - A
1:15

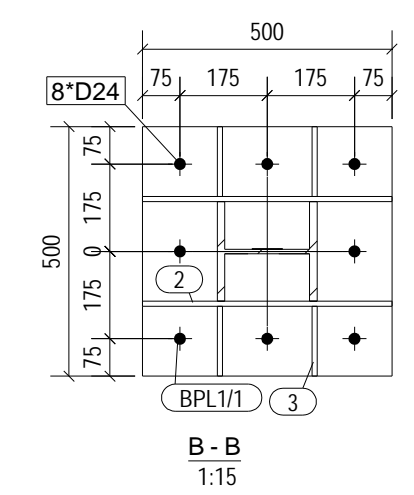

B - B
1:15

C1/6 No = 1

MATERIAL LIST FOR ASSEMBLY MK'D C1/6 1 No. Required						
Mark	Profile	Material	No.	Length	Area	Weight
1	HEB200	S235JR	1	4020	4.6	246.4
2	PL10*150	S235JR	2	500	0.2	5.9
3	PL10*150	S235JR	4	140	0.0	1.6
4	PL10*96	S235JR	2	170	0.0	1.2
11	PL1*20	S235JR	1	60	0.0	0.0
33	PL15*200	S235JR	1	700	0.3	16.5
34	PL15*200	S235JR	1	580	0.3	13.7
35	PL12*96	S235JR	4	170	0.0	1.5
BPL1/1	PL25*500	S235JR	1	500	0.6	49.1
DJ24/1	Assembly		1		0.8	25.9
DJ24/3	Assembly		1		0.9	30.3
DJ24/4	Assembly		1		0.9	29.8
DJ30/1	Assembly		1		0.9	33.5
				Total	10.1	472.0

No	REV MARK	REVISION DESCRIPTION	REV. DATE
CLIENT			
PRINT DATE FOR FABRICATION:			
PROJECT NAME		قم - سازه نگهدارنده	
DRAWING NAME		[C1.6]	ISSUED
MODELLED BY		09124932441	SCALE AS SHOWN
CHECKED BY			REVISION No. 0

GRID LOCATION	
DJ24/1	1-2/A
DJ24/1	1-2/B
DJ24/1	2-3/A
DJ24/1	2-3/B

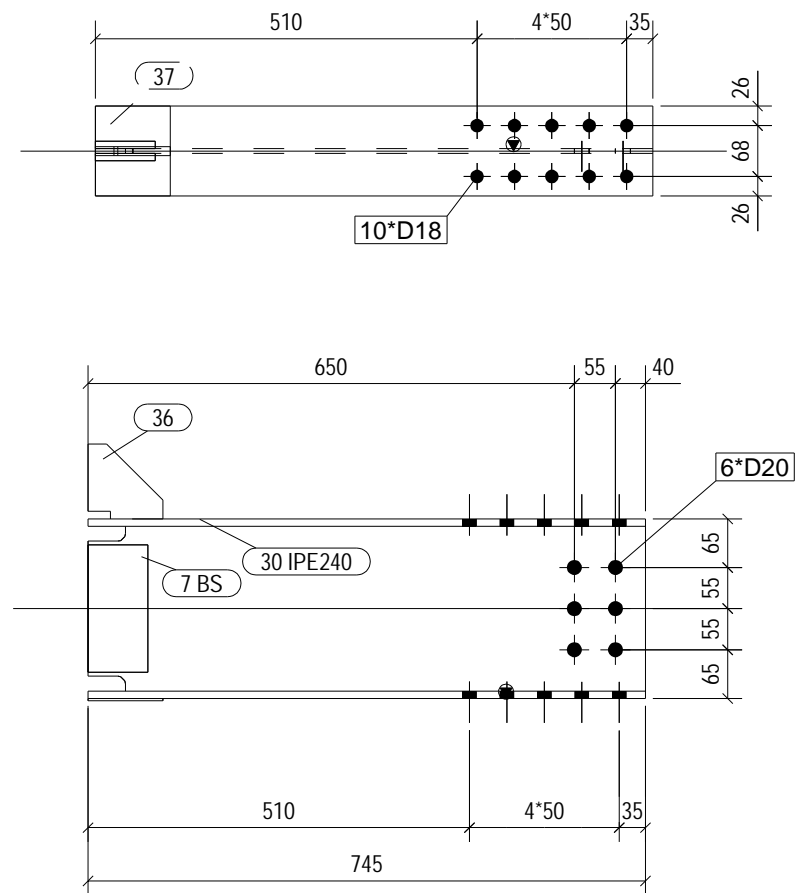

DJ24/1 No = 8

MATERIAL LIST FOR ASSEMBLY MK'D DJ24/1 No= 8					
Mark	Profile	Material	No.	Length	Weight
7	PL10*80	S235JR	2	170	1.1
30	IPE240	S235JR	1	745	22.9
36	PL12*100	S235JR	1	100	0.6
37	PL3*120	S235JR	1	100	0.3
Total				35.9	

No	REV MARK	REVISION DESCRIPTION	REV. DATE
CLIENT			
PRINT DATE FOR FABRICATION:			
PROJECT NAME		قم - سازه نگهداری	
DRAWING NAME		[DJ24.1]	ISSUED
MODELLED BY		09124932441	SCALE AS SHOWN
CHECKED BY			REVISION No. 0

teka structures

GRID LOCATION	
DJ24/2	2/1-A
DJ24/2	2/B>

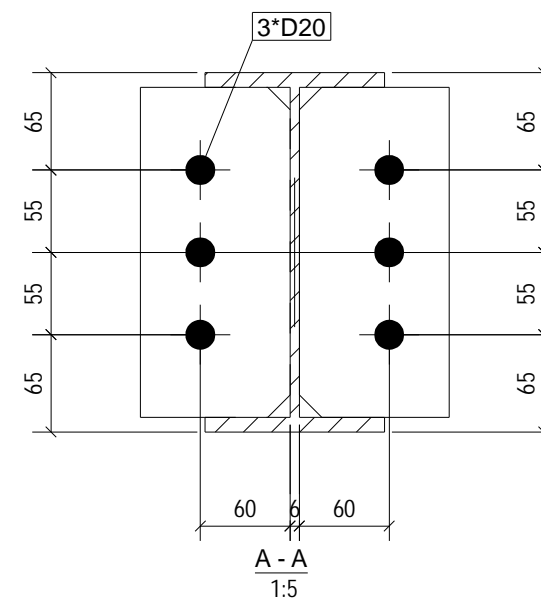
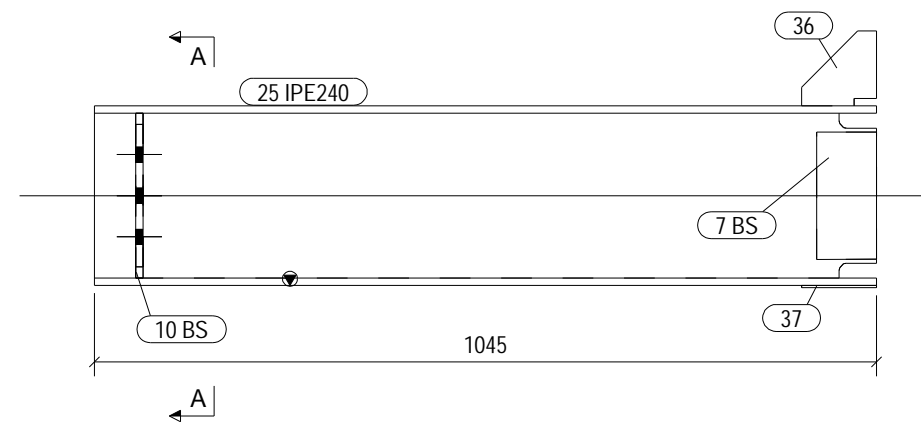
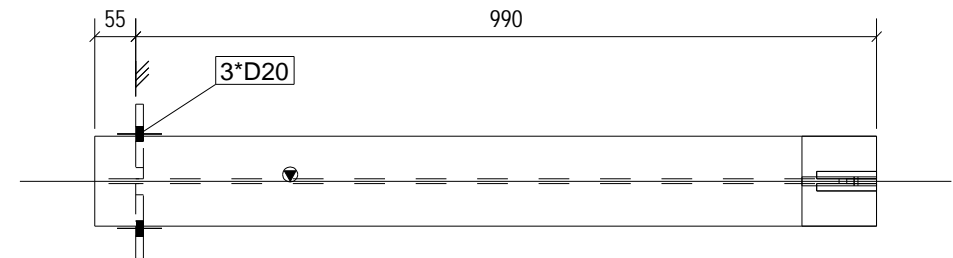

DJ24/2 No = 2

MATERIAL LIST FOR ASSEMBLY MK'D						DJ24/2	No= 2
Mark	Profile	Material	No.	Length	Weight		
7	PL10*80	S235JR	2	170	1.1		
10	PL10*100	S235JR	2	220	1.7		
25	IPE240	S235JR	1	1045	32.1		
36	PL12*100	S235JR	1	100	0.6		
37	PL3*120	S235JR	1	100	0.3		
Total					38.5		

No	REV MARK	REVISION DESCRIPTION	REV. DATE
CLIENT			
PRINT DATE FOR FABRICATION:			
PROJECT NAME		قم - سازه نگهداری	
DRAWING NAME		[DJ24.2]	ISSUED
MODELLED BY		09124932441	SCALE AS SHOWN
CHECKED BY			REVISION No. 0

lekia structures

GRID LOCATION	
DJ24/3	3>/A
DJ24/3	3>/B
DJ24/3	<1/A
DJ24/3	<1/B

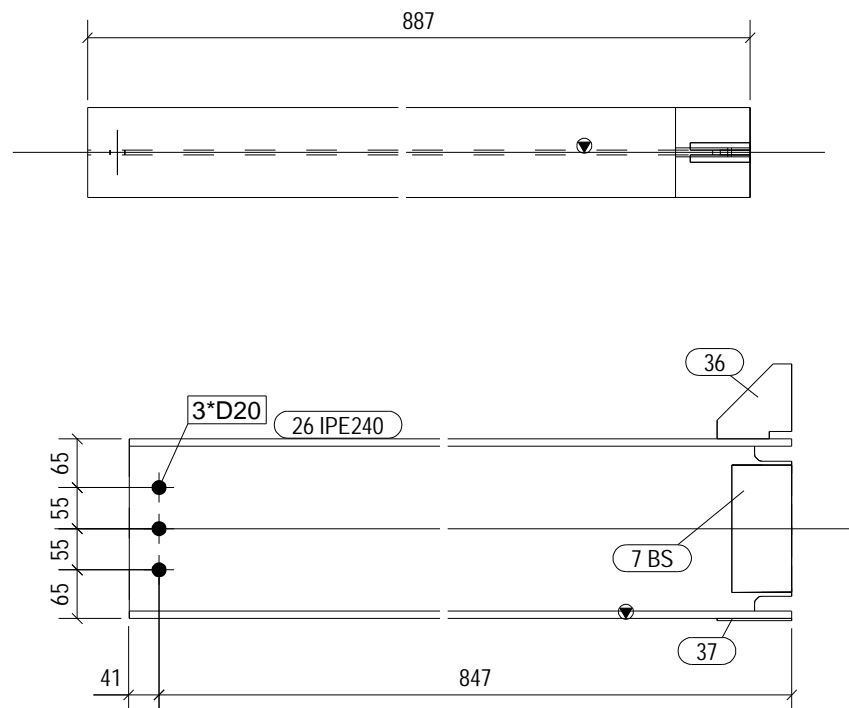

DJ24/3 No = 4

MATERIAL LIST FOR ASSEMBLY MK'D						DJ24/3	No= 4
Mark	Profile	Material	No.	Length	Weight		
7	PL10*80	S235JR	2	170	1.1		
26	IPE240	S235JR	1	887	27.2		
36	PL12*100	S235JR	1	100	0.6		
37	PL3*120	S235JR	1	100	0.3		
Total						30.3	

No	REV MARK	REVISION DESCRIPTION	REV. DATE
CLIENT			
PRINT DATE FOR FABRICATION:			
PROJECT NAME		قم - سازه نگهداری	
DRAWING NAME		[DJ24.3]	ISSUED
MODELLED BY		09124932441	SCALE AS SHOWN
CHECKED BY			REVISION No. 0

GRID LOCATION	
DJ24/4	1/1-A
DJ24/4	1/B>
DJ24/4	3/1-A
DJ24/4	3/B>

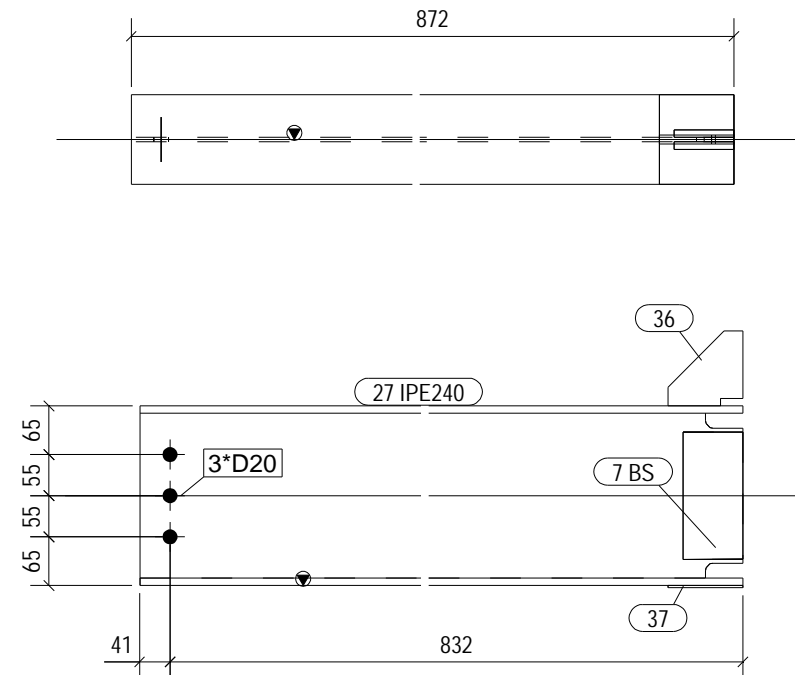

DJ24/4 No = 4

MATERIAL LIST FOR ASSEMBLY MK'D DJ24/4 No= 4					
Mark	Profile	Material	No.	Length	Weight
7	PL10*80	S235JR	2	170	1.1
27	IPE240	S235JR	1	872	26.8
36	PL12*100	S235JR	1	100	0.6
37	PL3*120	S235JR	1	100	0.3
Total				398	

No	REV MARK	REVISION DESCRIPTION	REV. DATE
CLIENT			
PRINT DATE FOR FABRICATION:			
PROJECT NAME		قم - سازه نگهداری	
DRAWING NAME		[DJ24.4]	ISSUED
MODELLED BY		09124932441	SCALE AS SHOWN
CHECKED BY			REVISION No. 0

GRID LOCATION	
DJ30/1	1/A-B
DJ30/1	2/A-B
DJ30/1	3/A-B

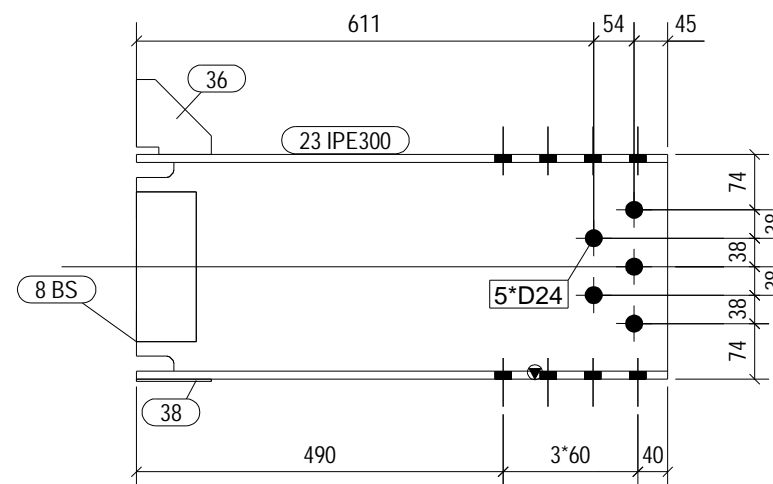
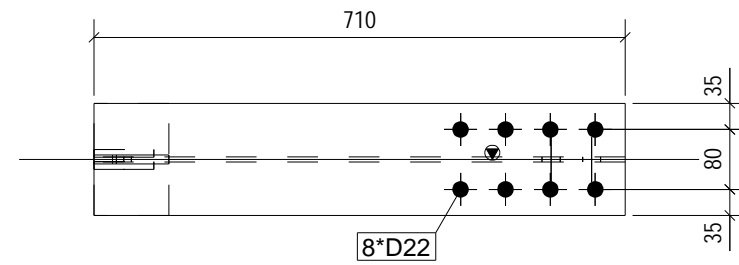

DJ30/1 No = 6

MATERIAL LIST FOR ASSEMBLY MK'D DJ30/1 No= 6					
Mark	Profile	Material	No.	Length	Weight
8	PL10*80	S235JR	2	200	1.3
23	IPE300	S235JR	1	710	30.0
36	PL12*100	S235JR	1	100	0.6
38	PL3*150	S235JR	1	100	0.4
				Total	32.5

No	REV MARK	REVISION DESCRIPTION	REV. DATE
CLIENT			
PRINT DATE FOR FABRICATION:			
PROJECT NAME		قم - سازه نگهداری	
DRAWING NAME		[DJ30.1]	ISSUED
MODELLED BY		09124932441	SCALE AS SHOWN
CHECKED BY			REVISION No. 0

GRID LOCATION	
J16/1	1-2/A-B
J16/1	2-3/A-B

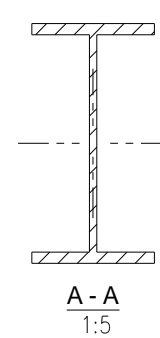
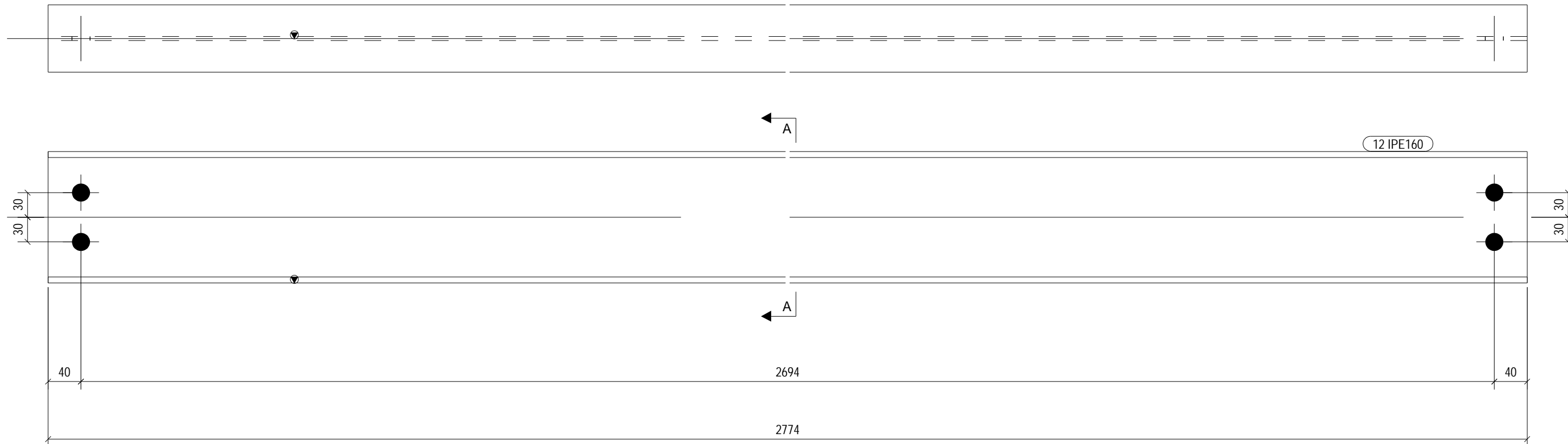

No	REV MARK	REVISION DESCRIPTION	REV. DATE
CLIENT			
PRINT DATE FOR FABRICATION:			
PROJECT NAME		قم - سازه نگهداری	
DRAWING NAME		[J16.1]	ISSUED
MODELLED BY		09124932441	SCALE AS SHOWN
CHECKED BY			REVISION No. 0

J16/1 No = 8

MATERIAL LIST FOR ASSEMBLY MK'D						J16/1	No= 8
Mark	Profile	Material	No.	Length	Weight		
12	IPE160	S235JR	1	2774	43.7		
Total					43.7		

GRID LOCATION	
J16/2	1-2/1-A
J16/2	1-2/B>
J16/2	2-3/1-A
J16/2	2-3/B>

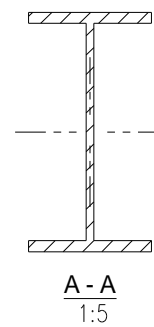
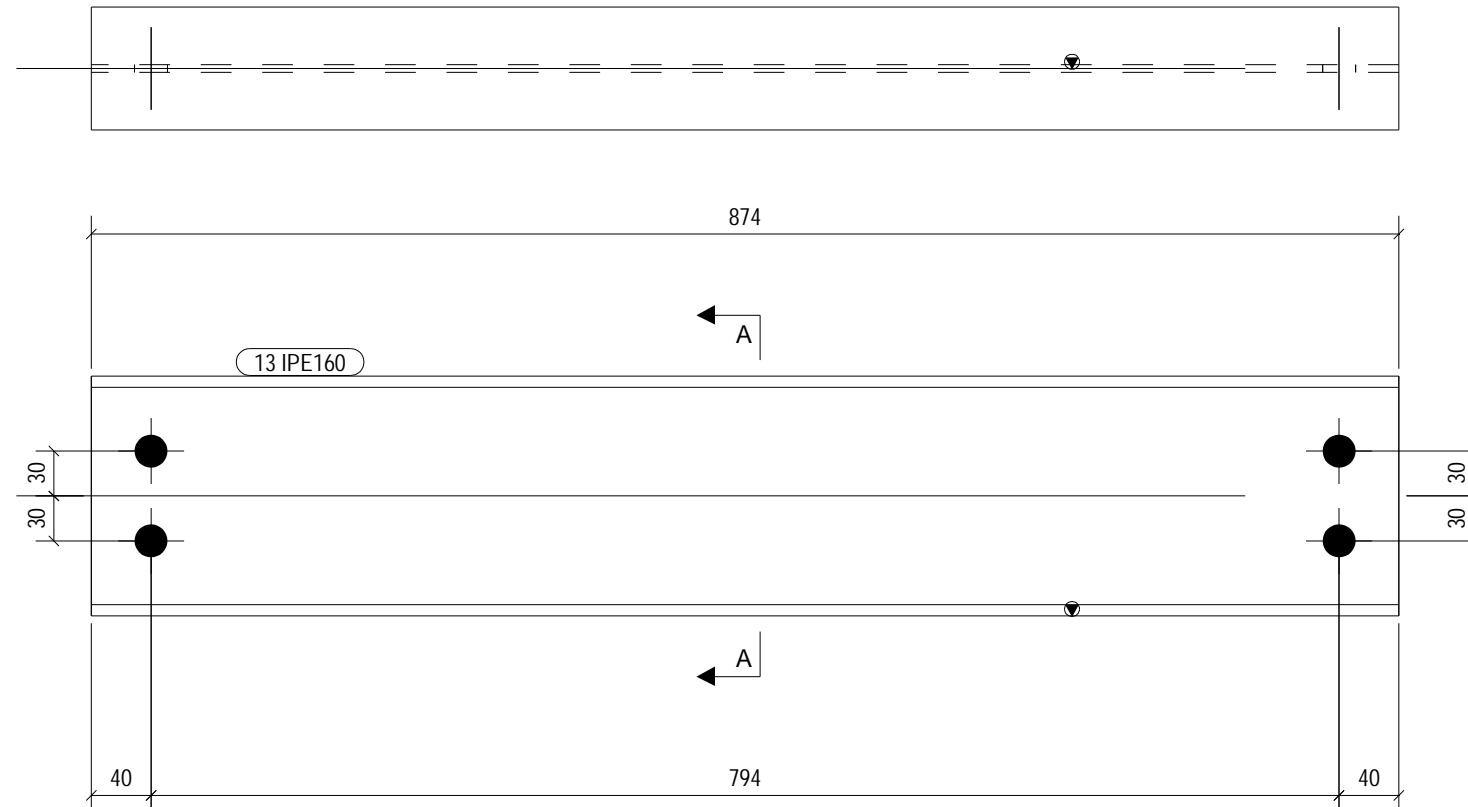

No	REV MARK	REVISION DESCRIPTION	REV. DATE
CLIENT			
PRINT DATE FOR FABRICATION:			
PROJECT NAME		قم - سازه نگهداری	
DRAWING NAME		[J16.2]	ISSUED
MODELLED BY		09124932441	SCALE AS SHOWN
CHECKED BY			REVISION No. 0

J16/2 No = 8

MATERIAL LIST FOR ASSEMBLY MK'D J16/2 No= 8					
Mark	Profile	Material	No.	Length	Weight
13	IPE160	S235JR	1	874	13.8
				Total	13.8

GRID LOCATION	
J22/1	1-2/A-B
J22/1	2-3/A-B

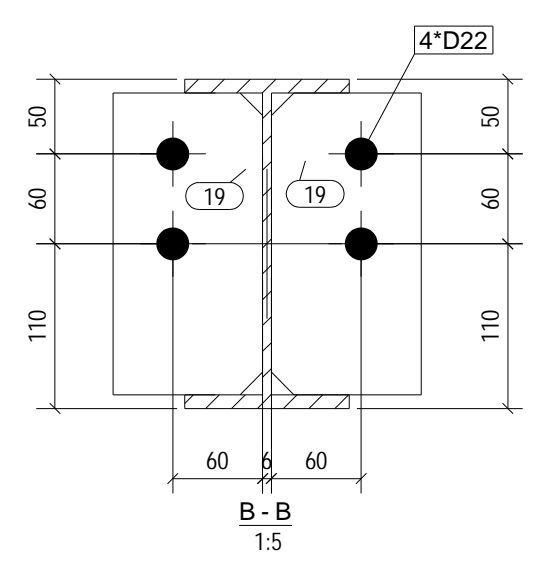
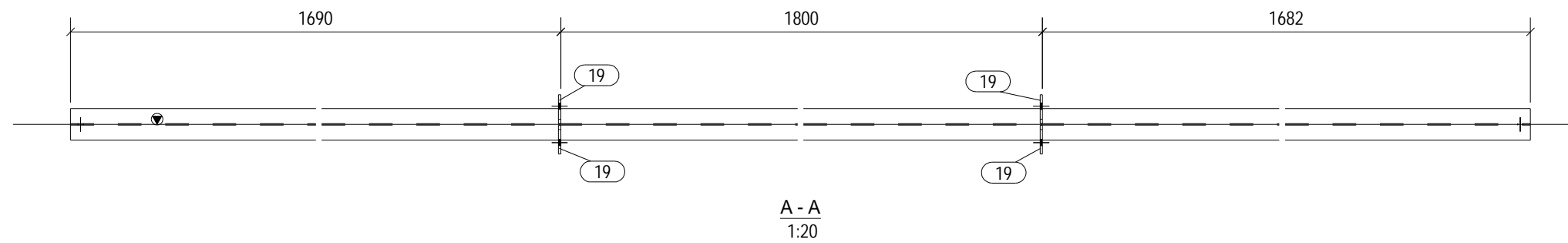
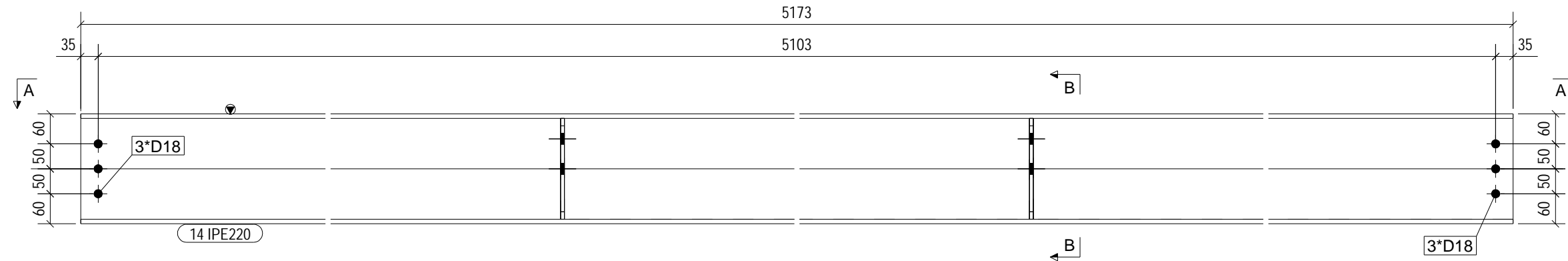

J22/1 No = 2

MATERIAL LIST FOR ASSEMBLY MK'D					
Mark	Profile	Material	No.	Length	Weight
14	IPE220	S235JR	1	5173	135.6
19	PL8*100	S235JR	4	202	1.3
				Total	140.5

No	REV MARK	REVISION DESCRIPTION	REV. DATE
CLIENT			
PRINT DATE FOR FABRICATION:			
PROJECT NAME		قم - سازه نگهداری	
DRAWING NAME		[J22.1]	ISSUED
MODELLED BY		09124932441	SCALE AS SHOWN
CHECKED BY			REVISION No. 0

GRID LOCATION	
J24/1	3->/1-B>
J24/1	<1/1-B>

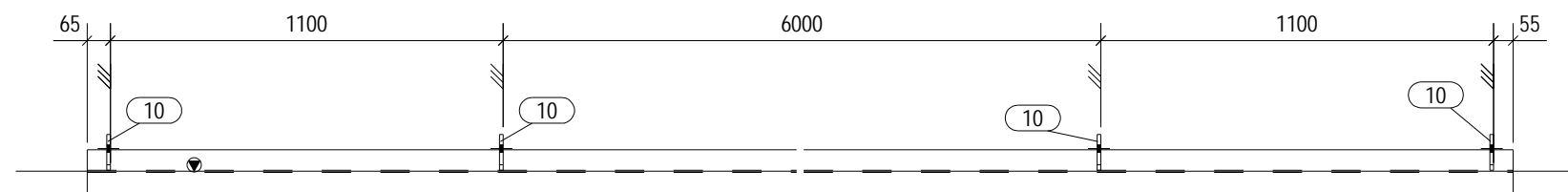
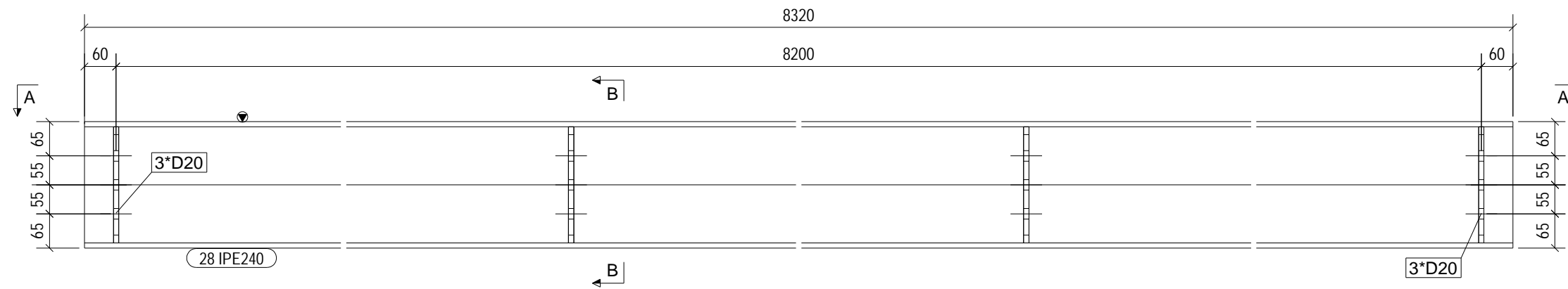

A - A
1:20

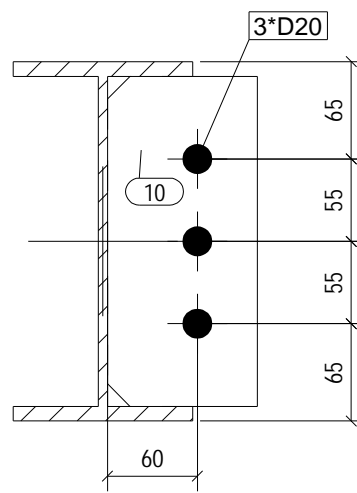

B - B
1:5

J24/1 No = 2

MATERIAL LIST FOR ASSEMBLY MK'D					
Mark	Profile	Material	No.	Length	Weight
10	PL10*100	S235JR	4	220	1.7
28	IPE240	S235JR	1	8320	255.3
				Total	263.2

No	REV MARK	REVISION DESCRIPTION	REV. DATE
		CLIENT	
PRINT DATE FOR FABRICATION:			
PROJECT NAME		قم - سازه نگهداری	
DRAWING NAME		[J24.1]	ISSUED
MODELLED BY		09124932441	SCALE AS SHOWN
CHECKED BY			REVISION No. 0

GRID LOCATION	
J24/3	2-3>/1-A
J24/3	<1-2/B>

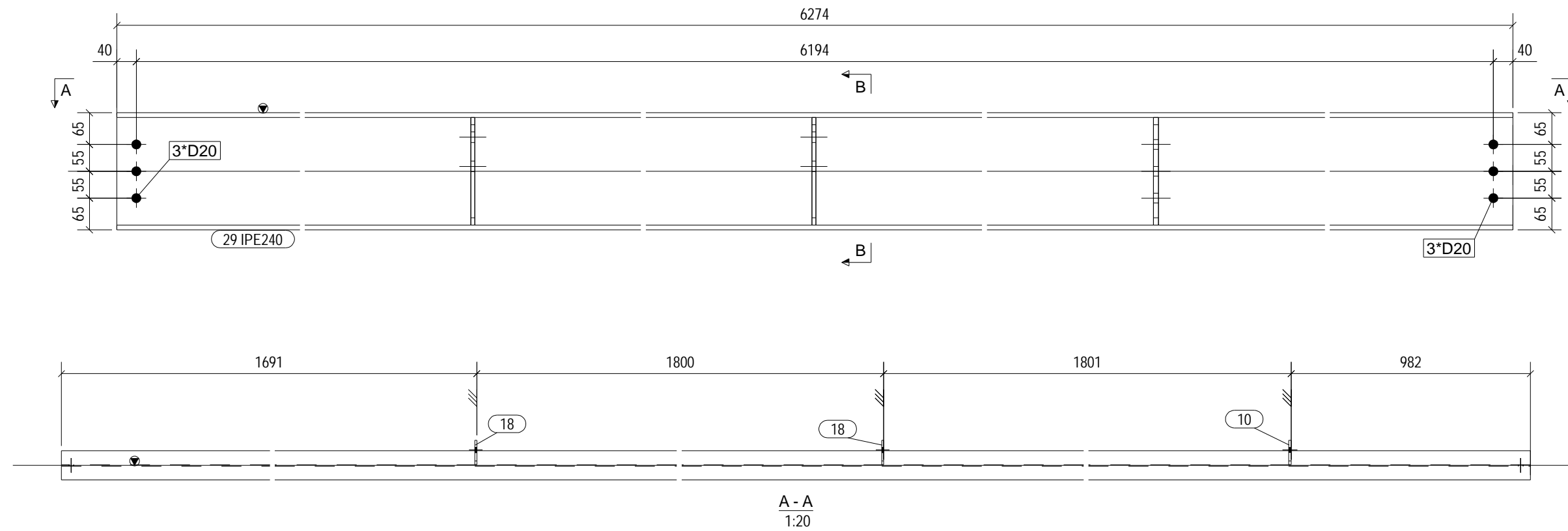

A - A
1:20

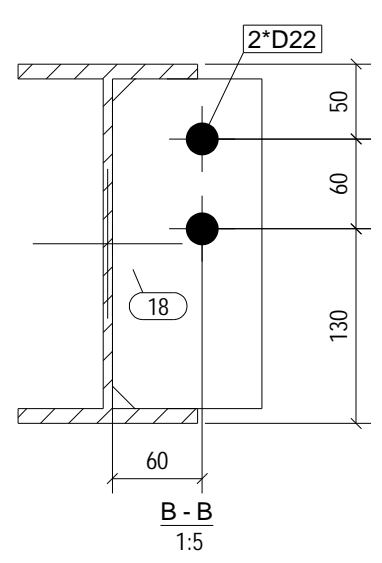

B - B
1:5

J24/3 No = 2

MATERIAL LIST FOR ASSEMBLY MK'D					
Mark	Profile	Material	No.	Length	Weight
10	PL10*100	S235JR	1	220	1.7
18	PL8*100	S235JR	2	220	1.4
29	IPE240	S235JR	1	6274	192.5
				Total	197.0

No	REV MARK	REVISION DESCRIPTION	REV. DATE
CLIENT			
PRINT DATE FOR FABRICATION:			
PROJECT NAME		قم - سازه نگهداری	
DRAWING NAME		[J24.3]	ISSUED
MODELLED BY		09124932441	SCALE AS SHOWN
CHECKED BY			REVISION No. 0

GRID LOCATION	
J24/4	2-3>/B>
J24/4	<1-2/1-A

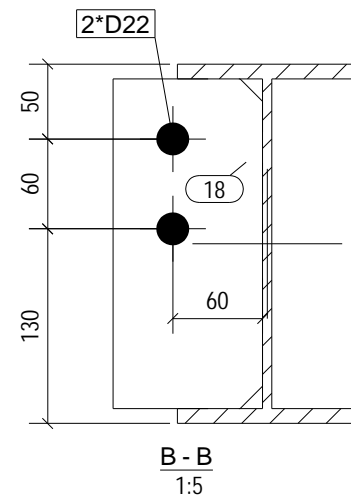
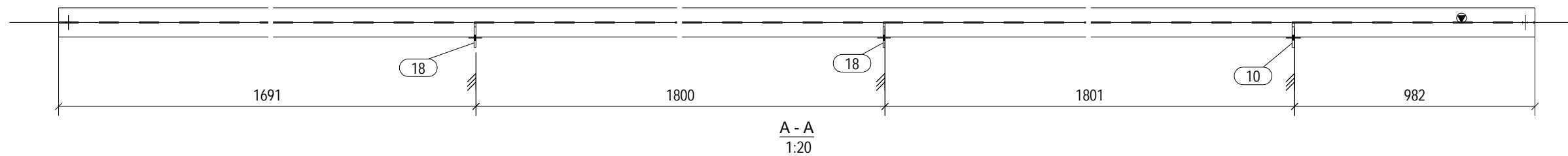
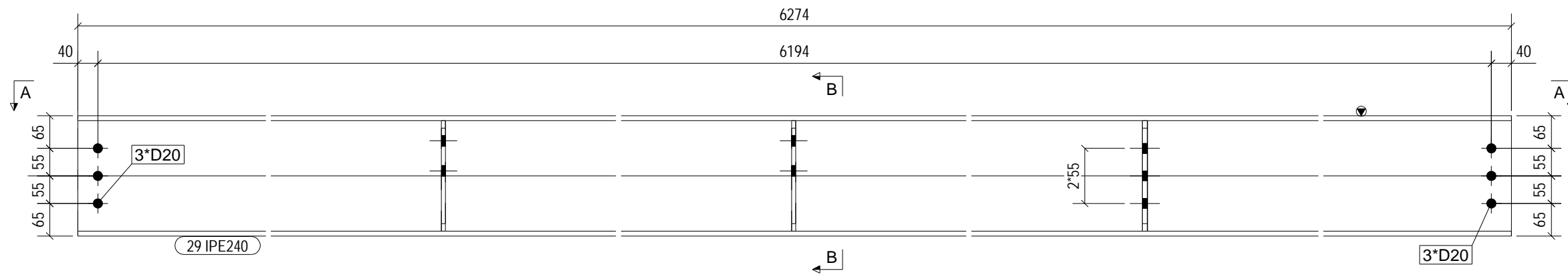

J24/4 No = 2

MATERIAL LIST FOR ASSEMBLY MK'D					
Mark	Profile	Material	No.	Length	Weight
10	PL10*100	S235JR	1	220	1.7
18	PL8*100	S235JR	2	220	1.4
29	IPE240	S235JR	1	6274	192.5
				Total	197.0

No	REV MARK	REVISION DESCRIPTION	REV. DATE
CLIENT			
PRINT DATE FOR FABRICATION:			
PROJECT NAME		قم - سازه نگهداری	
DRAWING NAME		[J24.4]	ISSUED
MODELLED BY		09124932441	SCALE AS SHOWN
CHECKED BY			REVISION No. 0

GRID LOCATION	
J24/5	1-2/A
J24/5	1-2/B
J24/5	2-3/A
J24/5	2-3/B

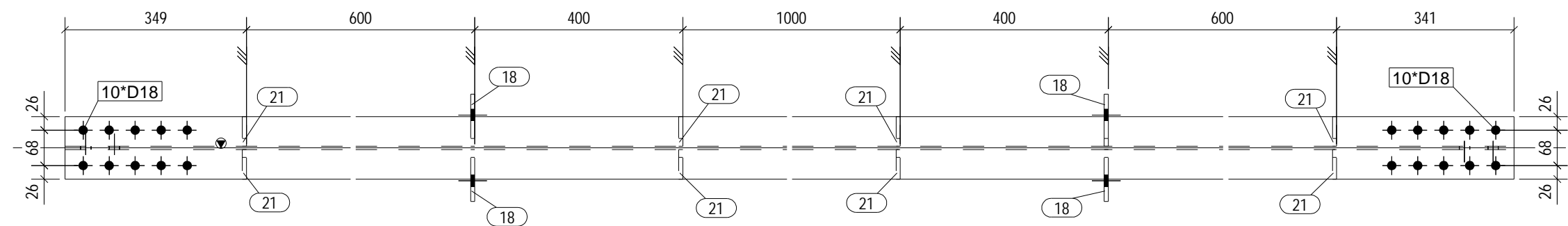
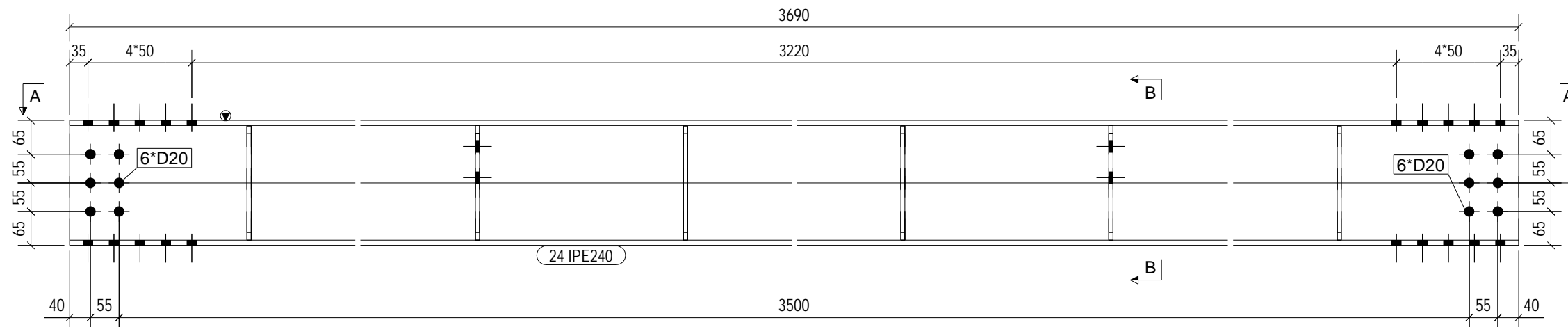

A - A
1:10

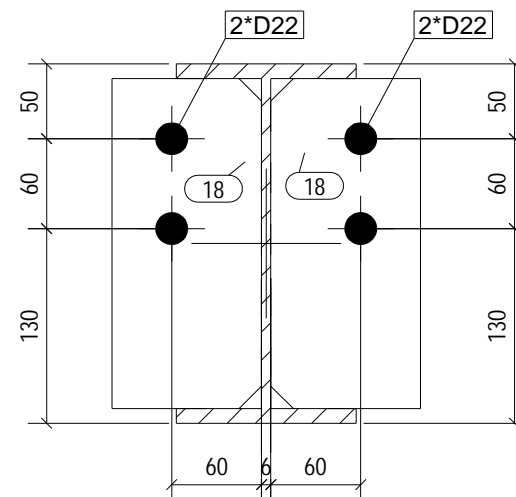

B - B
1:5

J24/5 No = 4

MATERIAL LIST FOR ASSEMBLY MK'D J24/5 No= 4					
Mark	Profile	Material	No.	Length	Weight
18	PL8*100	S235JR	4	220	1.4
21	PL8*57	S235JR	8	220	0.8
24	IPE240	S235JR	1	3690	113.2
Total				4110	115.4

No	REV MARK	REVISION DESCRIPTION	REV. DATE
CLIENT			
PRINT DATE FOR FABRICATION:			
PROJECT NAME		قم - سازه نگهداری	
DRAWING NAME		[J24.5]	ISSUED
MODELLED BY		09124932441	SCALE AS SHOWN
CHECKED BY			REVISION No. 0

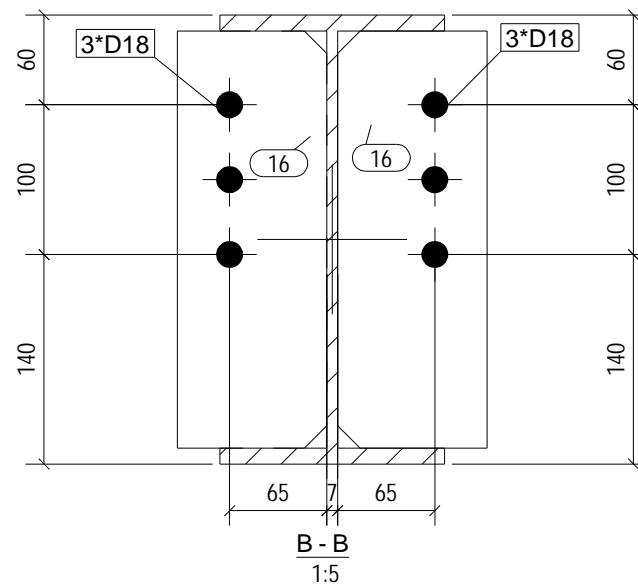
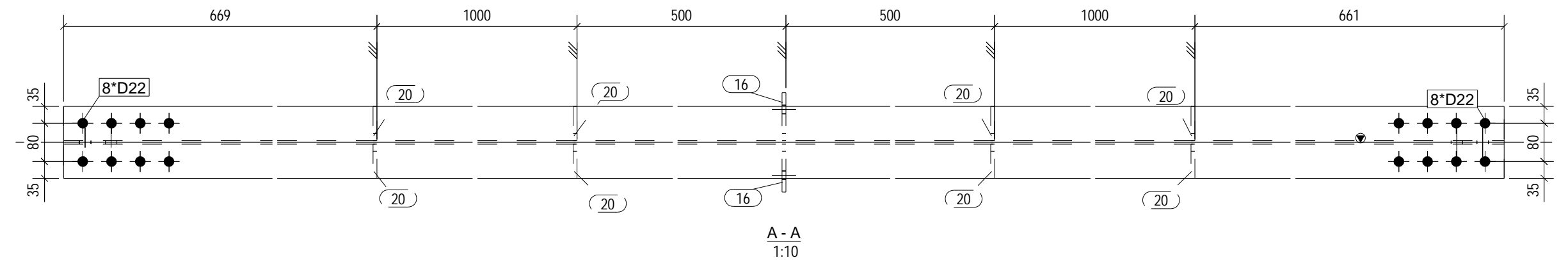
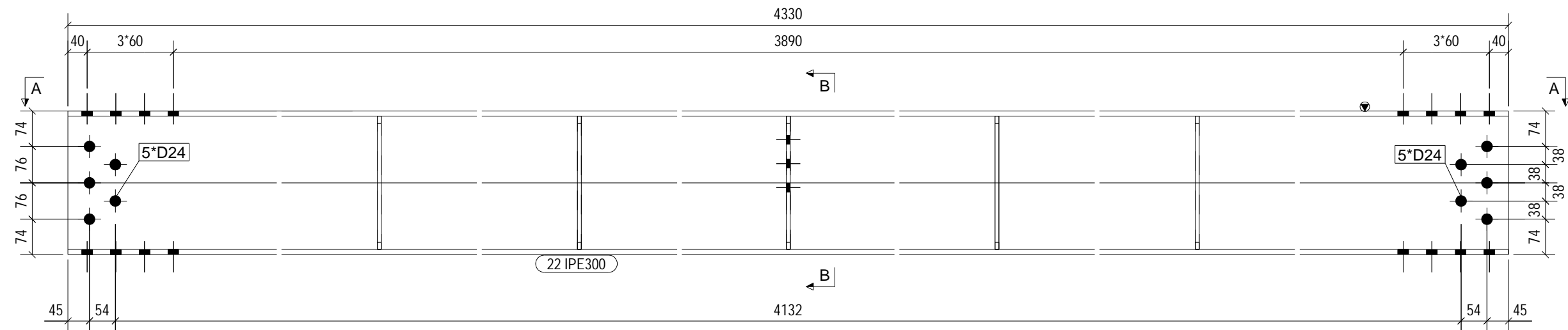

J30/1 No = 1

MATERIAL LIST FOR ASSEMBLY MK'D					
Mark	Profile	Material	No.	Length	Weight
16	PL8*100	S235JR	2	279	1.7
20	PL8*71	S235JR	8	279	1.2
22	IPE300	S235JR	1	4330	182.9
				Total	196.2

No	REV MARK	REVISION DESCRIPTION	REV. DATE
CLIENT			
PRINT DATE FOR FABRICATION:			
PROJECT NAME		قم - سازه نگهداری	
DRAWING NAME		[J30.1]	ISSUED
MODELLED BY		09124932441	SCALE AS SHOWN
CHECKED BY			REVISION No. 0

GRID LOCATION	
J30/2	1/A-B
J30/2	3/A-B

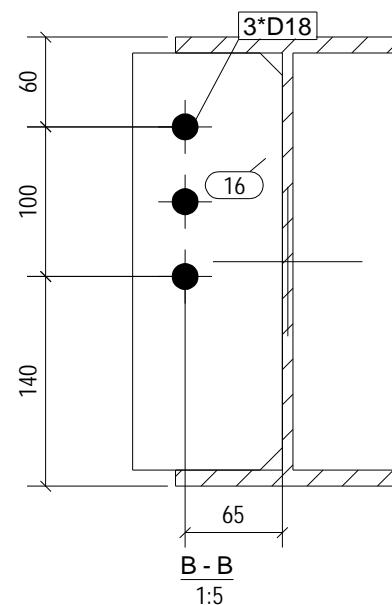
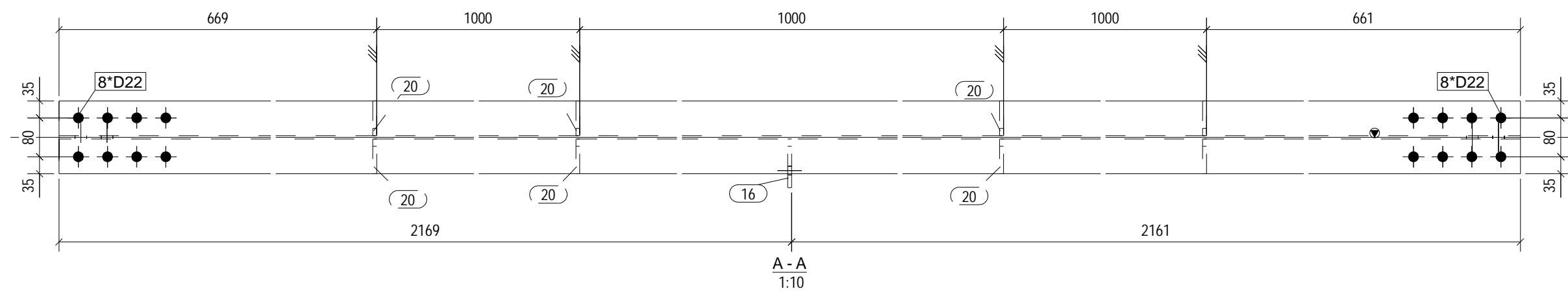
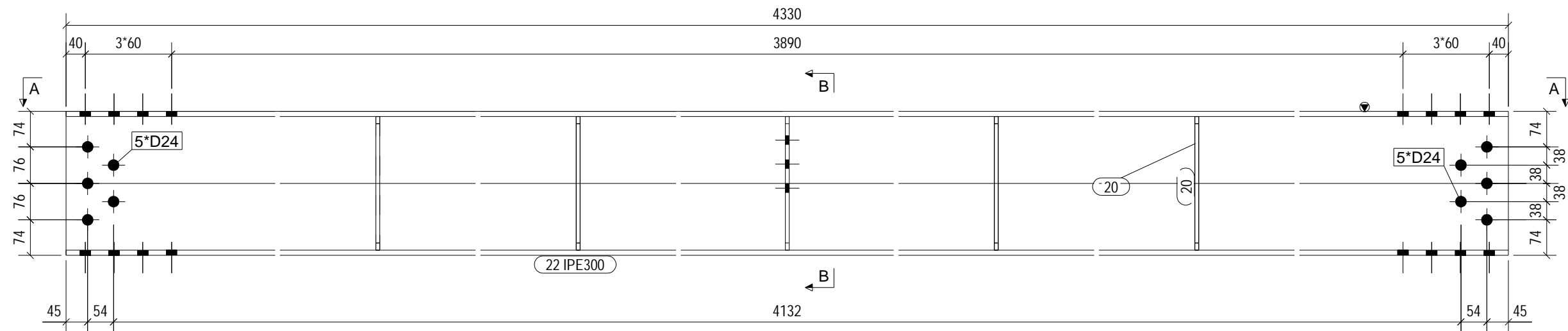

J30/2 No = 2

MATERIAL LIST FOR ASSEMBLY MK'D					
Mark	Profile	Material	No.	Length	Weight
16	PL8*100	S235JR	1	279	1.7
20	PL8*71	S235JR	8	279	1.2
22	IPE300	S235JR	1	4330	182.9
				Total	194.5

No	REV MARK	REVISION DESCRIPTION	REV. DATE
CLIENT			
PRINT DATE FOR FABRICATION:			
PROJECT NAME		قم - سازه نگهداری	
DRAWING NAME		[J30.2]	ISSUED
MODELLED BY		09124932441	SCALE AS SHOWN
CHECKED BY			REVISION No. 0

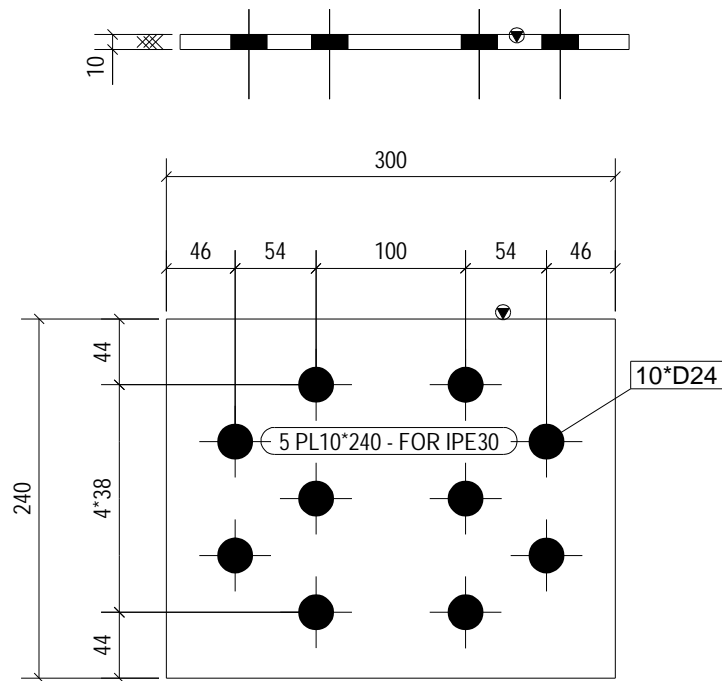

No. 12, Marked T/1

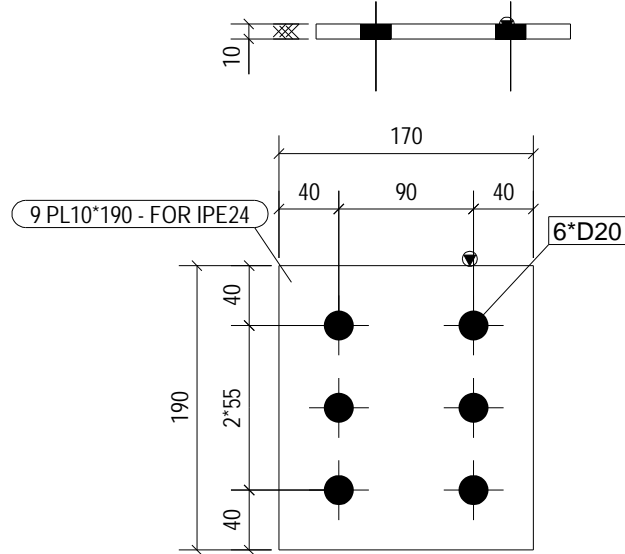

No. 32, Marked T/3

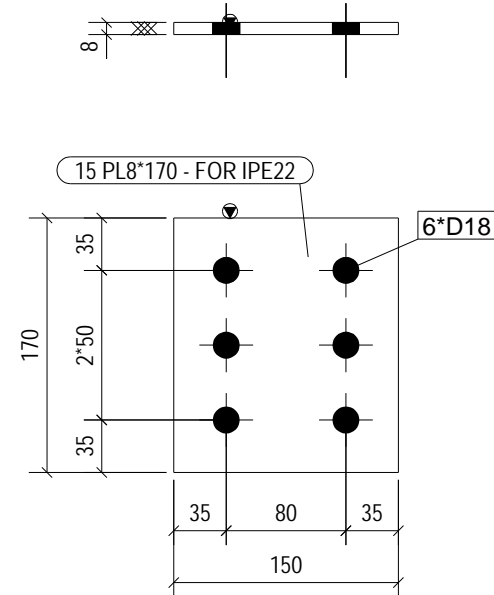

No. 8, Marked T/4

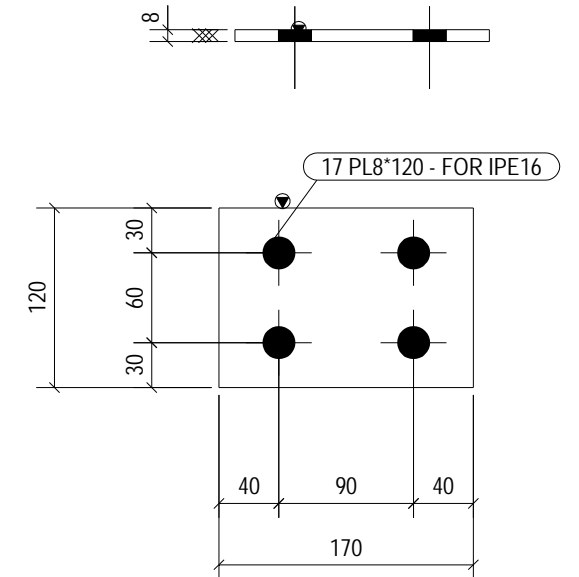

No. 64, Marked T/5

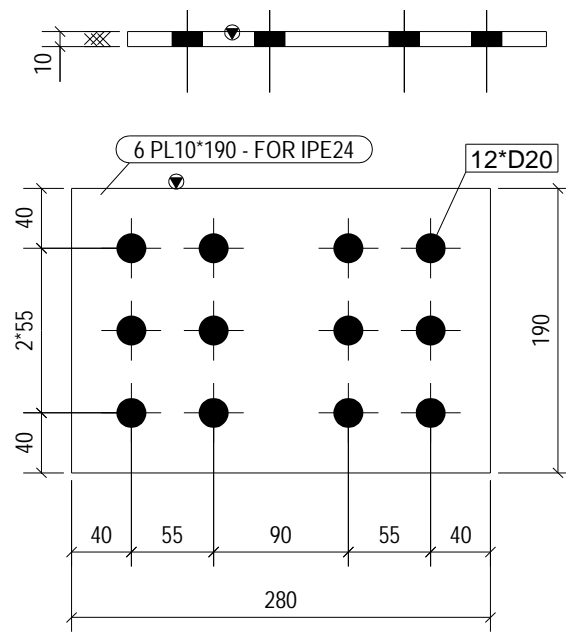

No. 16, Marked T/2

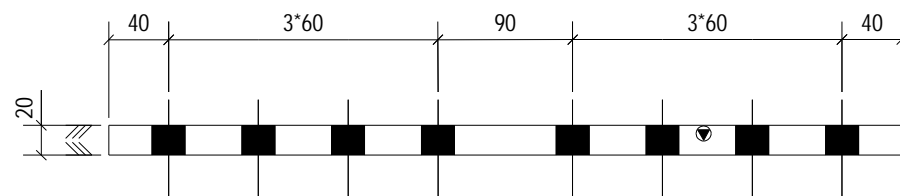

No. 12, Marked T/6

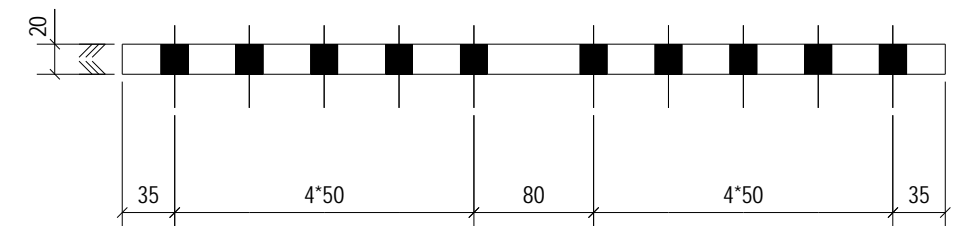

No. 16, Marked T/7

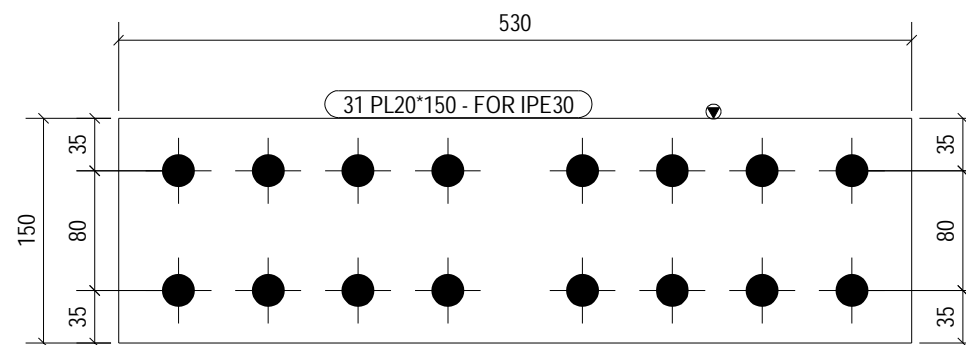
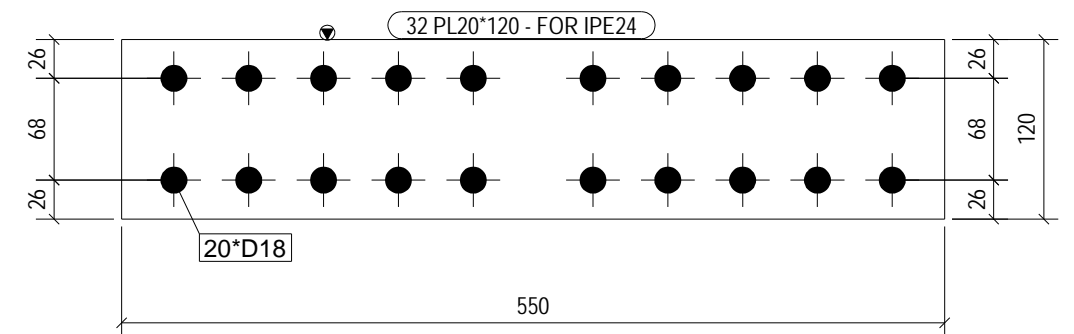

No	REV MARK	REVISION DESCRIPTION	REV. DATE
CLIENT			
PRINT DATE FOR FABRICATION:			
PROJECT NAME		قم - سازه نگهدارنده	
DRAWING NAME		[1]	ISSUED
MODELLED BY		09124932441	SCALE AS SHOWN
CHECKED BY			REVISION No. 0

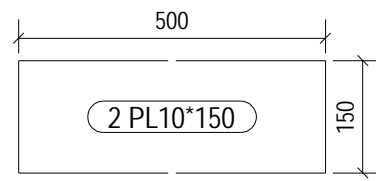

No. 12, Marked 2

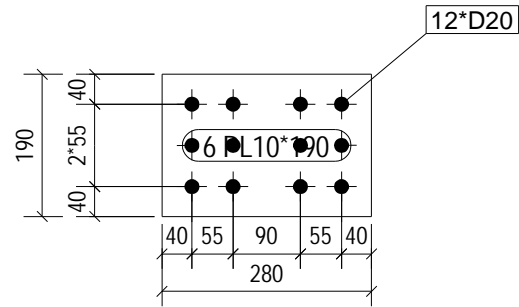

No. 16, Marked 6

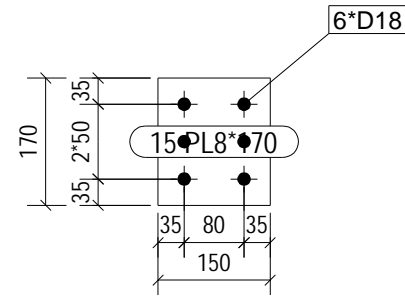

No. 8, Marked 15

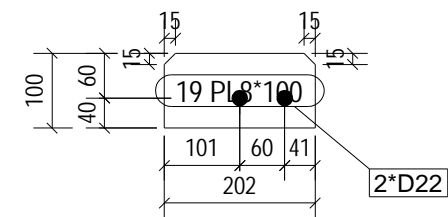

No. 8, Marked 19

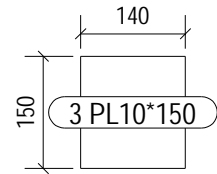

No. 24, Marked 3

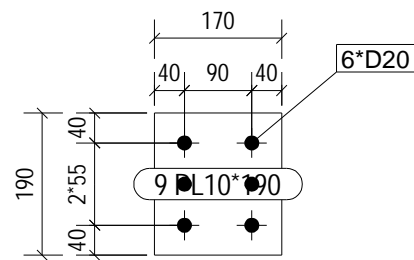

No. 32, Marked 9

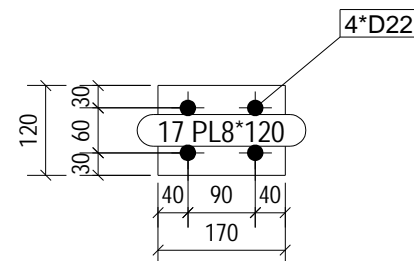

No. 64, Marked 17

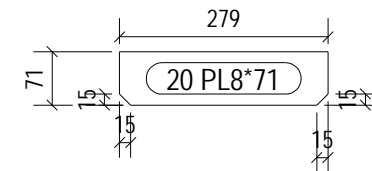

No. 24, Marked 20

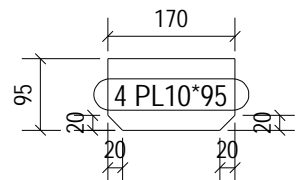

No. 12, Marked 4

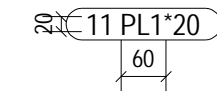

No. 6, Marked 11

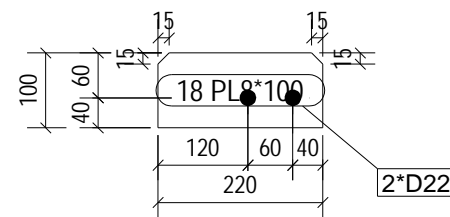

No. 24, Marked 18

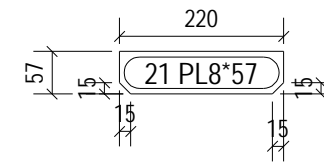

No. 32, Marked 21

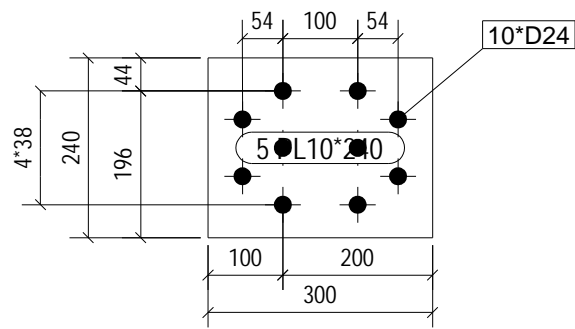

No. 12, Marked 5

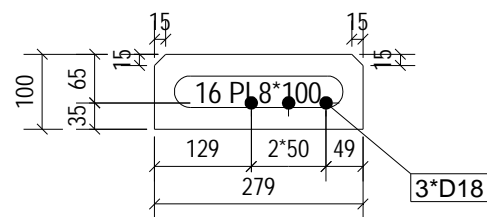

No. 4, Marked 16

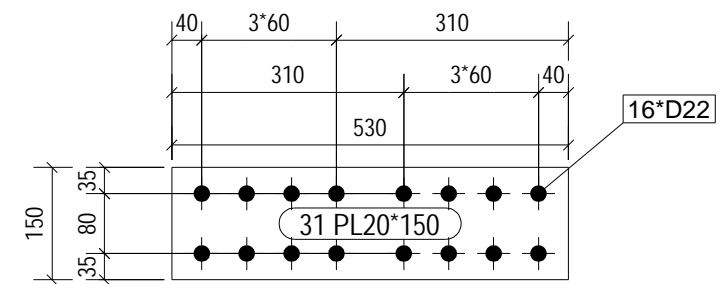

No. 12, Marked 31

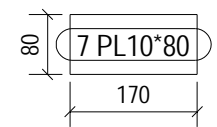

No. 36, Marked 7

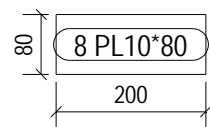

No. 12, Marked 8

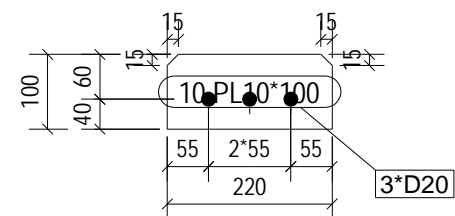

No. 16, Marked 10

No	REV MARK	REVISION DESCRIPTION	REV. DATE
CLIENT			
PRINT DATE FOR FABRICATION:			
PROJECT NAME	قم - سازه نگهداری		
DRAWING NAME	[2]	ISSUED	
MODELLED BY	09124932441	SCALE	AS SHOWN
CHECKED BY		REVISION No.	0

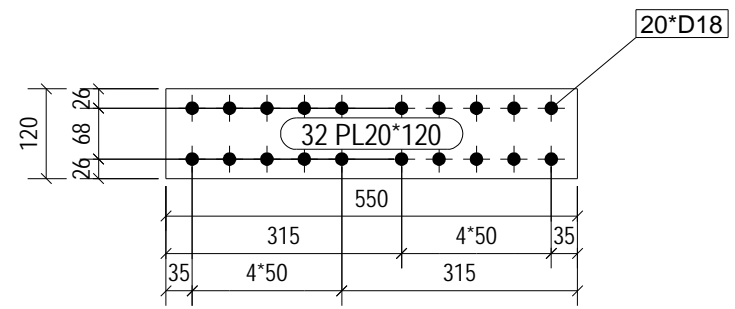

No. 16, Marked 32

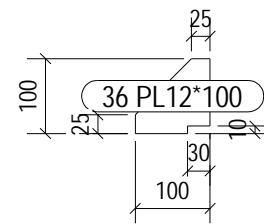

No. 24, Marked 36

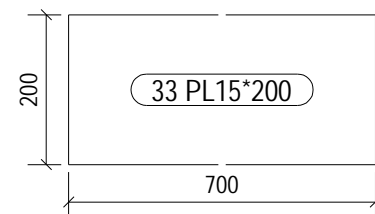

No. 6, Marked 33

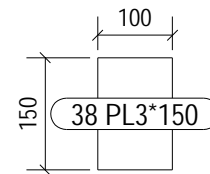

No. 6, Marked 38

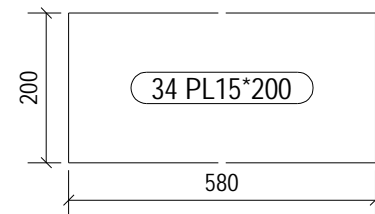

No. 6, Marked 34

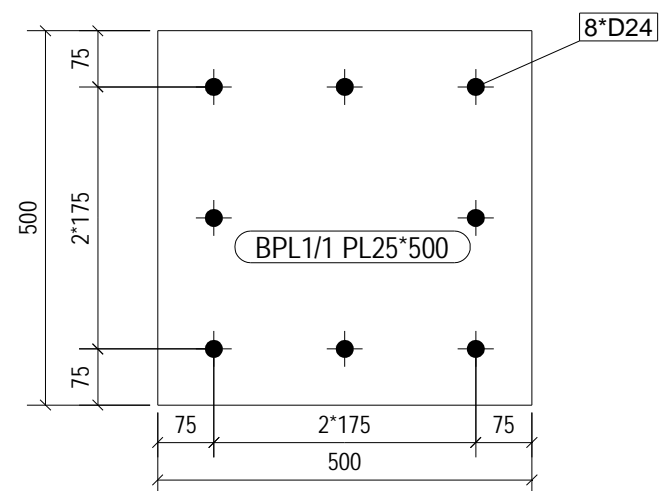

No. 6, Marked BPL1/1

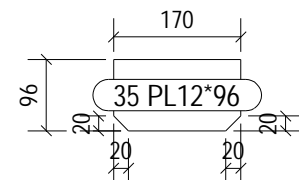

No. 24, Marked 35

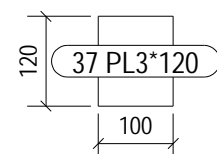

No. 18, Marked 37

No	REV MARK	REVISION DESCRIPTION	REV. DATE
CLIENT			
PRINT DATE FOR FABRICATION:			
PROJECT NAME	قم - سازه نگهداری		
DRAWING NAME	[3]	ISSUED	
MODELLED BY	09124932441	SCALE	AS SHOWN
CHECKED BY		REVISION No.	0